

See Sheet 1-A For Index of Sheets  
See Sheet 1-C for Conventional Symbols

STATE OF NORTH CAROLINA  
DIVISION OF HIGHWAYS

**GRANVILLE COUNTY**

**LOCATION:** Bridges No. 380023, 380022 and 380021 over  
Beaver Dam Creek on SR 1700 (Brassfield Road)

**TYPE OF WORK:** Paving, Grading, Drainage, Structures, Striping

STATE	STATE PROJECT REFERENCE NO.	SHEET NO.	TOTAL SHEETS
N.C.	17.BP.5.R.27, 17.BP.5.R.25, 17.BP.5.R.26	1	69
STATE PROJ. NO.	F.A. PROJ. NO.	DESCRIPTION	
17.BP.5.R.27		PE, RW, UTIL	
17.BP.5.R.25		PE, RW, UTIL	
17.BP.5.R.26		PE, RW, UTIL	

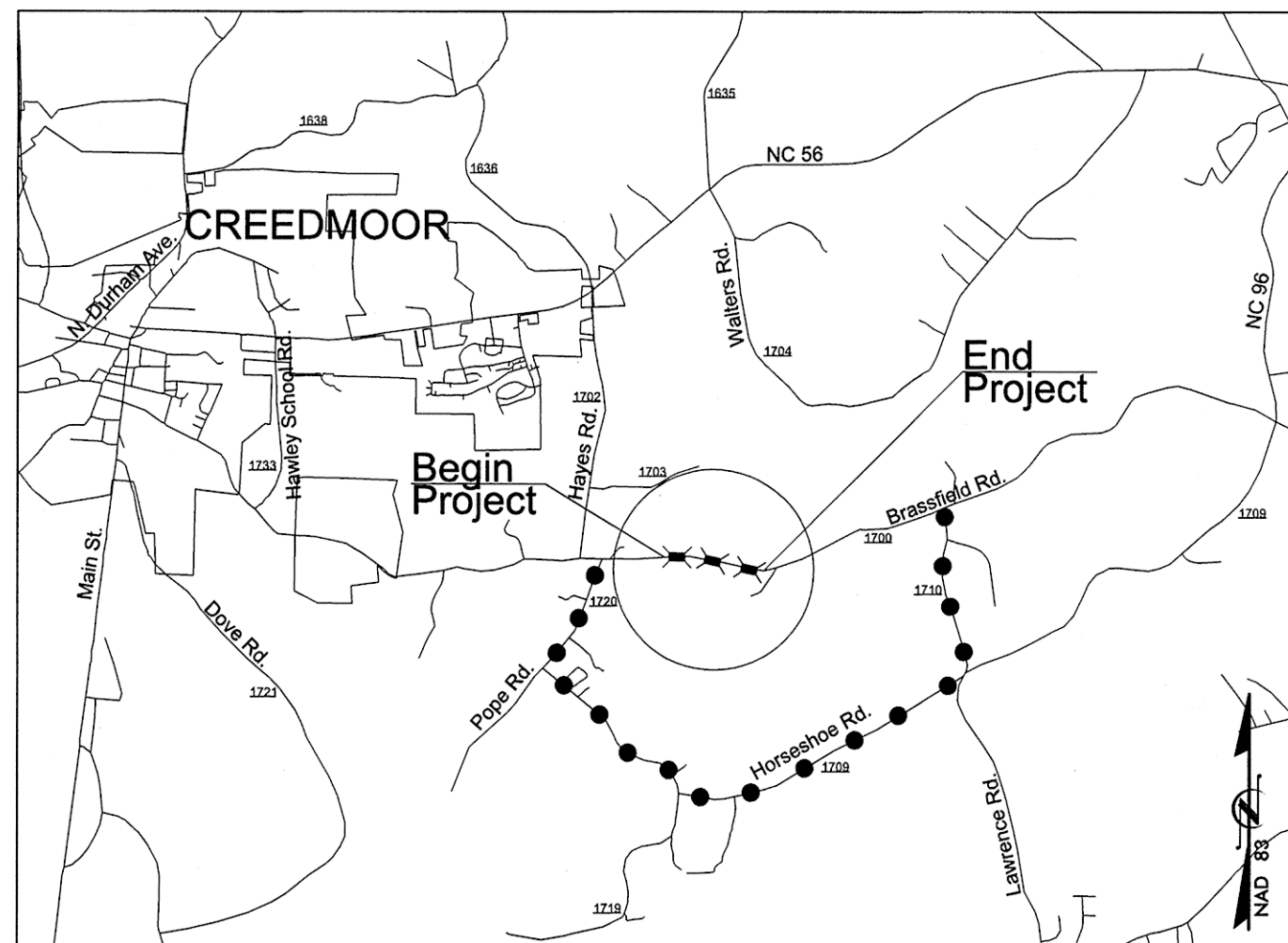

**VICINITY MAP**

●-●-● OFFSITE DETOUR

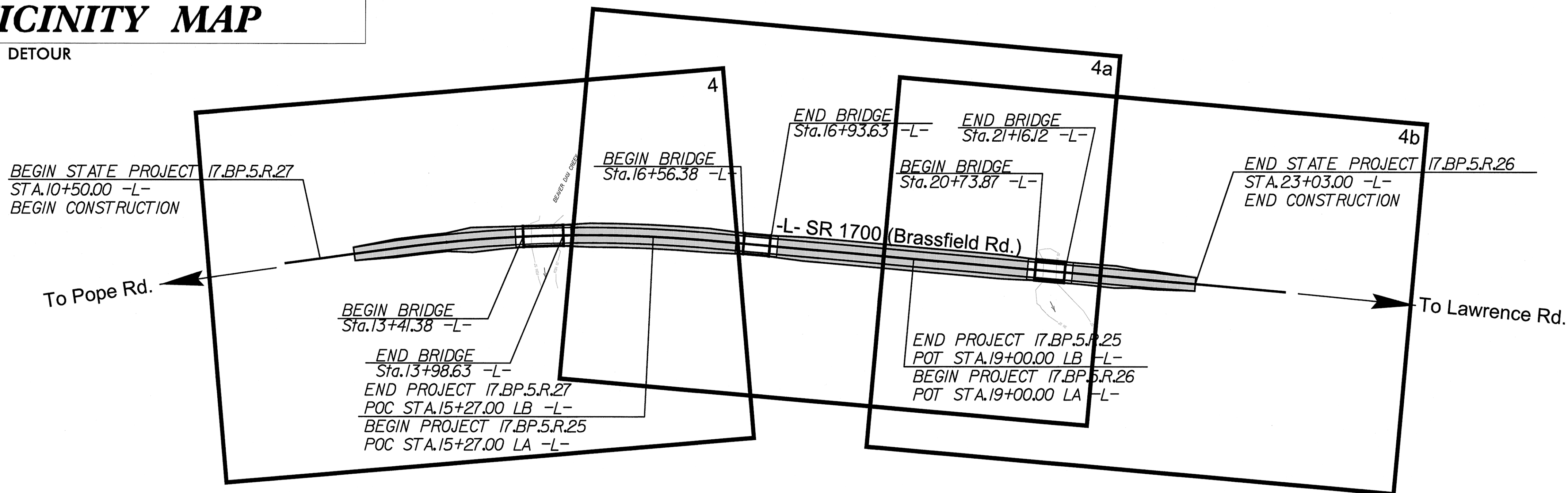

NOTE: A DESIGN EXCEPTION IS REQUIRED FOR SUPERELEVATION  
CLEARING ON THIS PROJECT SHALL BE ACCORDING TO THE LIMITS ESTABLISHED BY METHOD III

**CONTRACT: 17.BP.5.R.27, 17.BP.5.R.25, 17.BP.5.R.26**

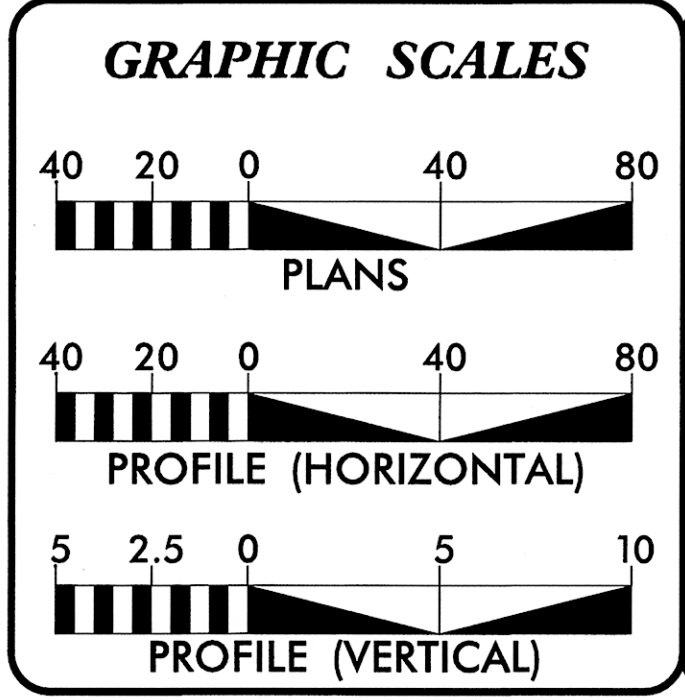

**DESIGN DATA**

ADT 2011	=	2,500
ADT 2025	=	4,800
DHV	=	10 %
D	=	50 %
T	=	6 % *
V	=	60 MPH
* TTST	=	DUAL
FUNC CLASS	=	MINOR COLLECTOR
<b>SUB REGIONAL TIER</b>		

**PROJECT LENGTH**

LENGTH OF ROADWAY	=	0.212 MILES
LENGTH OF STRUCTURE 380023	=	0.010 MILES
LENGTH OF STRUCTURE 380022	=	0.007 MILES
LENGTH OF STRUCTURE 380021	=	0.008 MILES
TOTAL LENGTH OF PROJECT	=	0.237 MILES

Plans prepared for the  
North Carolina  
Department of Transportation  
In the Office of:

**MARTIN ALEXIOU BRVSON**  
4000 WestChase Boulevard, Suite 530  
Raleigh, NC 27607  
NC License No. C-3496  
Transportation Planning & Design  
Traffic Engineering

2012 STANDARD SPECIFICATIONS

**RIGHT OF WAY DATE:**  
Aug. 13, 2012

**LETTING DATE:**  
March 2013

**Keith Lewis, PE**  
PROJECT ENGINEER

**Laura Fisher, PE**  
PROJECT DESIGN ENGINEER

**HYDRAULICS ENGINEER**

*John G. Delt*  
SIGNATURE:

**ROADWAY DESIGN ENGINEER**

*Laura C. Fisher*  
SIGNATURE:

Professional Engineer seals for John G. Delt and Laura C. Fisher.

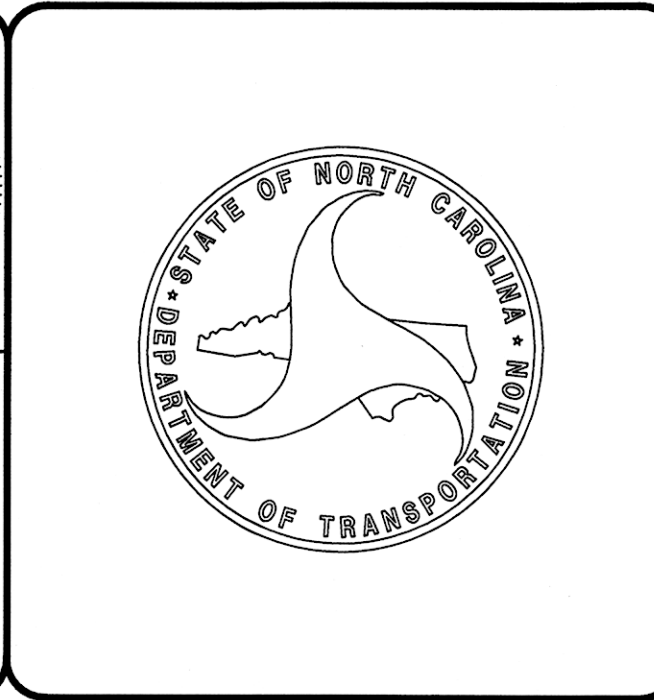

2/21/2013 17BP5R26\_rdy\_tsh.dgn ifisher



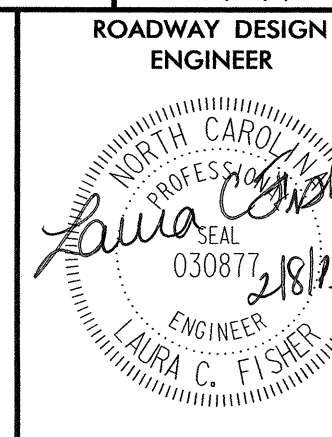

## GENERAL NOTES

GENERAL NOTES: 2012 SPECIFICATIONS

EFFECTIVE: 01-17-12  
REVISED:

**GRADING AND SURFACING OR RESURFACING AND WIDENING:**

THE GRADE LINES SHOWN DENOTE THE FINISHED ELEVATION OF THE PROPOSED SURFACING AT GRADE POINTS SHOWN ON THE TYPICAL SECTIONS. WHERE NO GRADE LINES ARE SHOWN, THE PROFILES SHOWN DENOTE THE TOP ELEVATION OF THE EXISTING PAVEMENT ALONG THE CENTERLINE OF SURVEY ON WHICH THE PROPOSED RESURFACING WILL BE PLACED. GRADE LINES MAY BE ADJUSTED BY THE ENGINEER IN ORDER TO SECURE A PROPER TIE-IN.

**CLEARING:**

CLEARING ON THIS PROJECT SHALL BE PERFORMED TO THE LIMITS ESTABLISHED BY METHOD III.

**SUPERELEVATION:**

ALL CURVES ON THIS PROJECT SHALL BE SUPERELEVATED IN ACCORDANCE WITH STD. NO. 225.04 USING THE RATE OF SUPERELEVATION AND RUNOFF SHOWN ON THE PLANS. SUPERELEVATION IS TO BE REVOLVED ABOUT THE GRADE POINTS SHOWN ON THE TYPICAL SECTIONS.

**SHOULDER CONSTRUCTION:**

ASPHALT, EARTH, AND CONCRETE SHOULDER CONSTRUCTION ON THE HIGH SIDE OF SUPERELEVATED CURVES SHALL BE IN ACCORDANCE WITH STD. NO. 560.01.

**GUARDRAIL:**

THE GUARDRAIL LOCATIONS SHOWN ON THE PLANS MAY BE ADJUSTED DURING CONSTRUCTION AS DIRECTED BY THE ENGINEER. THE CONTRACTOR SHOULD CONSULT WITH THE ENGINEER PRIOR TO ORDERING GUARDRAIL MATERIAL.

**END BENTS:**

THE SURVEYOR SHALL CHECK THE STRUCTURE END BENT PLANS, DETAILS, AND CROSS-SECTIONS PRIOR TO SETTING THE SLOPE STAKES FOR THE EMBANKMENT OR EXCAVATION APPROACHING A BRIDGE.

**RIGHT-OF-WAY MARKERS:**

ALL RIGHT-OF-WAY MARKERS ON THIS PROJECT SHALL BE PLACED BY CONTRACTOR.

**UTILITIES:**

ALL UTILITIES HAVE BEEN REMOVED FROM PROJECT AREA, OR ARE NOT ANTICIPATED TO BE IN CONFLICT WITH THE PROJECT.

## LIST OF ROADWAY STANDARD DRAWINGS

EFFECTIVE: 01-17-12  
REVISED:

**2012 ROADWAY ENGLISH STANDARD DRAWINGS**

The following Roadway Standards as appear in "Roadway Standard Drawings" Highway Design Branch N.C. Department of Transportation - Raleigh, N.C., Dated January, 2012 are applicable to this project and by reference hereby are considered a part of these plans"

STD.NO.	TITLE
<b>DIVISION 2 - EARTHWORK</b>	
200.03	Method of Clearing - Method III
225.02	Guide for Grading Subgrade -Secondary and Local
225.04	Method of Obtaining Superelevation - Two Lane Pavement
<b>DIVISION 3 - PIPE CULVERTS</b>	
300.01	Method of Pipe Installation
<b>DIVISION 4 - MAJOR STRUCTURES</b>	
422.11	Reinforced Bridge Approach Fills - Sub Regional Tier
<b>DIVISION 5 - SUBGRADE, BASES AND SHOULDERS</b>	
560.01	Method of Shoulder Construction - High Side of Superelevated Curve - Method I
<b>DIVISION 8 - INCIDENTALS</b>	
806.02	Concrete Right-of-Way Marker
840.00	Concrete Base Pad for Drainage Structures
840.25	Anchorage for Frame
840.29	Frames and Narrow Slot Flat Grates
840.35	Traffic Bearing Grated Drop Inlet - for Cast Iron Double Frame and Grates
840.46	Traffic Bearing Precast Drainage Structure
840.66	Drainage Structure Steps
846.01	Concrete Curb, Gutter and Curb & Gutter
862.01	Guardrail Placement
862.02	Guardrail Installation
862.03	Structure Anchor Units
876.02	Guide for Rip Rap at Pipe Outlets
876.04	Drainage Ditches with Class 'B' Rip Rap

### INDEX OF SHEETS

<u>SHEET NUMBER</u>	<u>SHEET</u>
1	TITLE SHEET
1-A	INDEX OF SHEETS, GENERAL NOTES, AND LIST OF STANDARD DRAWINGS
1-B	MODIFIED CONCRETE FLUME STANDARD DETAIL
1-C	CONVENTIONAL SYMBOLS
2	TYPICAL SECTIONS
3	SUMMARY OF DRAINAGE QUANTITIES, GUARDRAIL SUMMARY, AND EARTHWORK SUMMARY
4 thru 4b	PLAN SHEETS
5	PROFILE SHEET
TCP-1 thru TCP-2	TRAFFIC CONTROL PLANS
X-1 thru X-9	CROSS SECTIONS
EC-1 thru EC-5	EROSION CONTROL PLANS
RF-1	REFORESTATION PLAN
S-1 thru S-12	STRUCTURE PLANS - BRIDGE NO. 380023
S-1 thru S-12	STRUCTURE PLANS - BRIDGE NO. 380022
S-1 thru S-12	STRUCTURE PLANS - BRIDGE NO. 380021



STATE OF NORTH CAROLINA  
DEPT. OF TRANSPORTATION  
DIVISION OF HIGHWAYS  
RALEIGH, N.C.

STATE OF NORTH CAROLINA  
DEPT. OF TRANSPORTATION  
DIVISION OF HIGHWAYS  
RALEIGH, N.C.

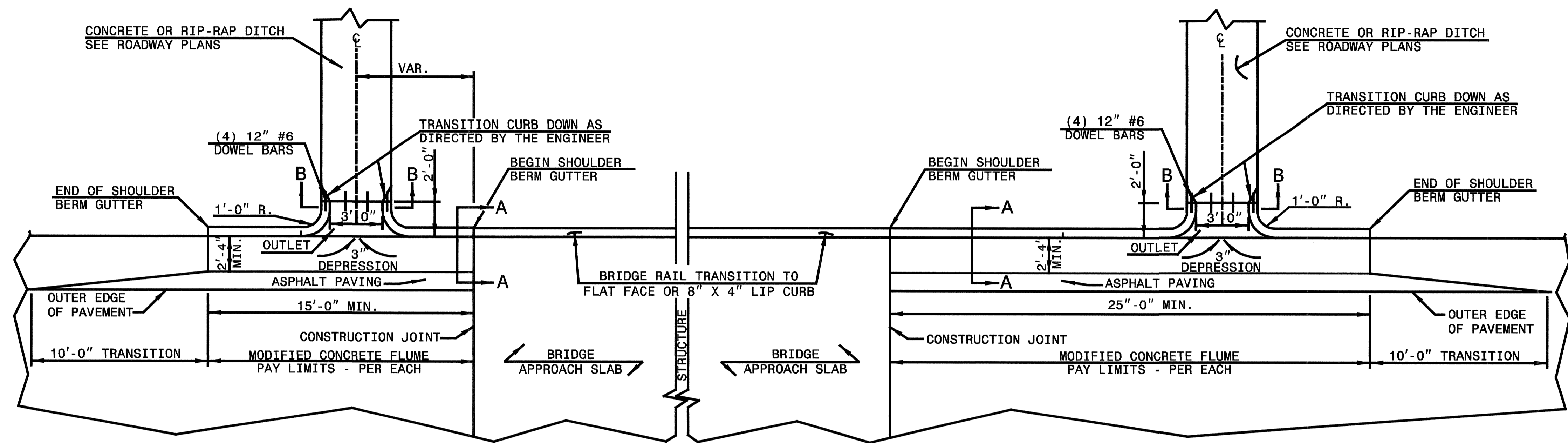

ENGLISH DETAIL DRAWING FOR  
**MODIFIED CONCRETE FLUME**  
WITH CONCRETE OR RIP-RAP DITCH

ENGLISH DETAIL DRAWING FOR  
**MODIFIED CONCRETE FLUME**  
WITH CONCRETE OR RIP-RAP DITCH

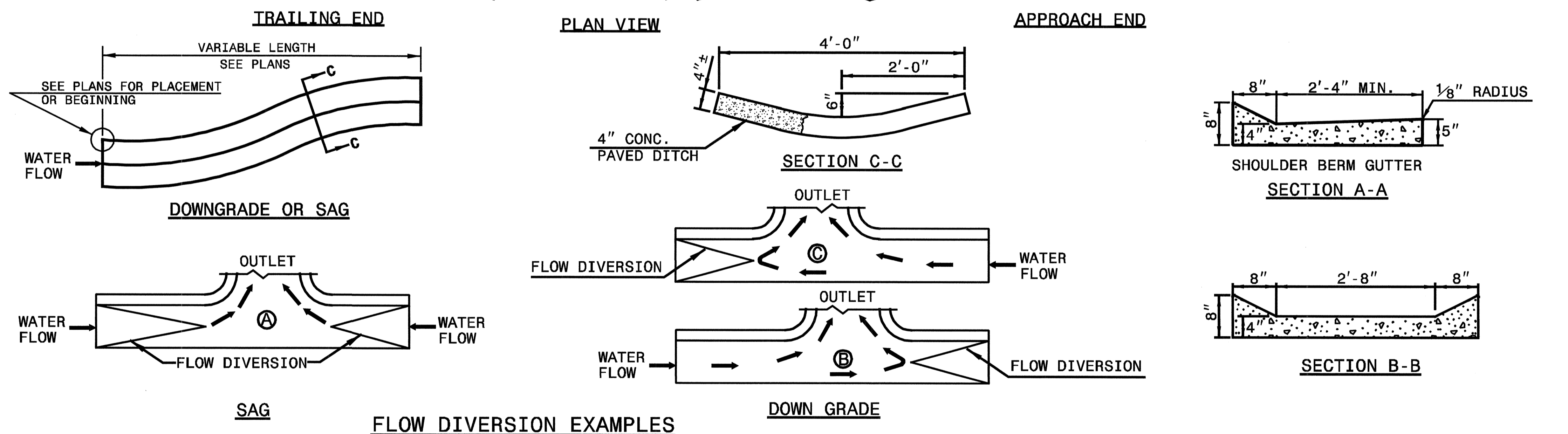

- NOTES:
- CONSTRUCT MODIFIED CONCRETE FLUME AND SHOULDER BERM GUTTER IN ACCORDANCE WITH THIS DETAIL.
  - CONSTRUCT CONCRETE DITCH IN ACCORDANCE WITH STD. DWG. NO. 850.01.
  - CONSTRUCT RIP RAP LINED DITCH IN ACCORDANCE WITH THIS DETAIL, IF CALLED FOR IN PLANS.
  - CONCRETE OR RIP RAP LINED DITCH SHALL BE THE TYPE AND LENGTH SPECIFIED BY THE ROADWAY PLANS. THE DITCH SHALL TERMINATE AS SHOWN ON THE PLANS. IF NO TERMINATION IS INDICATED PLACE RIP-RAP AT THE END OF THE DITCH AS INDICATED BY STD. DWG. 876.02 FOR AN 18" PIPE. TRANSITIONS FROM THE DITCH TO TERMINATION SHALL BE AS DIRECTED BY THE ENGINEER.
  - MODIFICATIONS SHALL BE AS DICTATED BY SITE CONDITIONS AND DIRECTED BY THE ENGINEER.













Note: Not to Scale

\*S.U.E. = Subsurface Utility Engineering





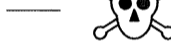
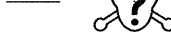





STATE OF NORTH CAROLINA  
DIVISION OF HIGHWAYS

# CONVENTIONAL PLAN SHEET SYMBOLS











### BOUNDARIES AND PROPERTY:

State Line	_____
County Line	_____
Township Line	_____
City Line	_____
Reservation Line	_____
Property Line	_____
Existing Iron Pin	_____ 
Property Corner	_____ 
Property Monument	_____ 
Parcel/Sequence Number	_____ 
Existing Fence Line	_____ 
Proposed Woven Wire Fence	_____ 
Proposed Chain Link Fence	_____ 
Proposed Barbed Wire Fence	_____ 
Existing Wetland Boundary	_____ 
Proposed Wetland Boundary	_____ 
Existing Endangered Animal Boundary	_____ 
Existing Endangered Plant Boundary	_____ 
Known Soil Contamination: Area or Site	_____ 
Potential Soil Contamination: Area or Site	_____ 





### BUILDINGS AND OTHER CULTURE:

Gas Pump Vent or U/G Tank Cap	_____ 
Sign	_____ 
Well	_____ 
Small Mine	_____ 
Foundation	_____ 
Area Outline	_____ 
Cemetery	_____ 
Building	_____ 
School	_____ 
Church	_____ 
Dam	_____ 



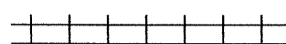

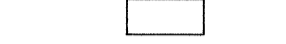

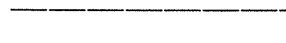







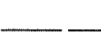

### HYDROLOGY:

Stream or Body of Water	_____
Hydro, Pool or Reservoir	_____ 
Jurisdictional Stream	_____ 
Buffer Zone 1	_____ 
Buffer Zone 2	_____ 
Flow Arrow	_____ 
Disappearing Stream	_____ 
Spring	_____ 
Wetland	_____ 
Proposed Lateral, Tail, Head Ditch	_____ 
False Sump	_____ 

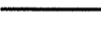







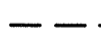
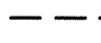

### RAILROADS:

Standard Gauge	_____ 
RR Signal Milepost	_____ 
Switch	_____ 
RR Abandoned	_____ 
RR Dismantled	_____ 





### RIGHT OF WAY:

Baseline Control Point	_____ 
Existing Right of Way Marker	_____ 
Existing Right of Way Line	_____ 
Proposed Right of Way Line	_____ 
Proposed Right of Way Line with Iron Pin and Cap Marker	_____ 
Proposed Right of Way Line with Concrete or Granite RW Marker	_____ 
Proposed Control of Access Line with Concrete C/A Marker	_____ 
Existing Control of Access	_____ 
Proposed Control of Access	_____ 
Existing Easement Line	_____ 
Proposed Temporary Construction Easement	_____ 
Proposed Temporary Drainage Easement	_____ 
Proposed Permanent Drainage Easement	_____ 
Proposed Permanent Drainage / Utility Easement	_____ 
Proposed Permanent Utility Easement	_____ 
Proposed Temporary Utility Easement	_____ 
Proposed Aerial Utility Easement	_____ 
Proposed Permanent Easement with Iron Pin and Cap Marker	_____ 

### ROADS AND RELATED FEATURES:







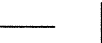

Existing Edge of Pavement	_____ 
Existing Curb	_____ 
Proposed Slope Stakes Cut	_____ 
Proposed Slope Stakes Fill	_____ 
Proposed Curb Ramp	_____ 
Existing Metal Guardrail	_____ 
Proposed Guardrail	_____ 
Existing Cable Guiderail	_____ 
Proposed Cable Guiderail	_____ 
Equality Symbol	_____ 
Pavement Removal	_____ 

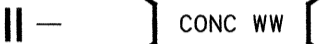
### VEGETATION:











Single Tree	_____ 
Single Shrub	_____ 
Hedge	_____ 
Woods Line	_____ 

Orchard	_____ 
Vineyard	_____ 

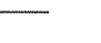











### EXISTING STRUCTURES:

MAJOR:	
Bridge, Tunnel or Box Culvert	_____ 
Bridge Wing Wall, Head Wall and End Wall	_____ 
MINOR:	
Head and End Wall	_____ 
Pipe Culvert	_____ 
Footbridge	_____ 
Drainage Box: Catch Basin, DI or JB	_____ 
Paved Ditch Gutter	_____ 
Storm Sewer Manhole	_____ 
Storm Sewer	_____ 



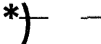

### UTILITIES:

POWER:	
Existing Power Pole	_____ 
Proposed Power Pole	_____ 
Existing Joint Use Pole	_____ 
Proposed Joint Use Pole	_____ 
Power Manhole	_____ 
Power Line Tower	_____ 
Power Transformer	_____ 
U/G Power Cable Hand Hole	_____ 
H-Frame Pole	_____ 
Recorded U/G Power Line	_____ 
Designated U/G Power Line (S.U.E.*)	_____ 



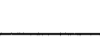
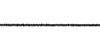

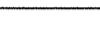



### TELEPHONE:

Existing Telephone Pole	_____ 
Proposed Telephone Pole	_____ 
Telephone Manhole	_____ 
Telephone Booth	_____ 
Telephone Pedestal	_____ 
Telephone Cell Tower	_____ 
U/G Telephone Cable Hand Hole	_____ 
Recorded U/G Telephone Cable	_____ 
Designated U/G Telephone Cable (S.U.E.*)	_____ 
Recorded U/G Telephone Conduit	_____ 
Designated U/G Telephone Conduit (S.U.E.*)	_____ 
Recorded U/G Fiber Optics Cable	_____ 
Designated U/G Fiber Optics Cable (S.U.E.*)	_____ 





### WATER:

Water Manhole	_____ 
Water Meter	_____ 
Water Valve	_____ 
Water Hydrant	_____ 
Recorded U/G Water Line	_____ 
Designated U/G Water Line (S.U.E.*)	_____ 
Above Ground Water Line	_____ 



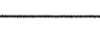

### TV:

TV Satellite Dish	_____ 
TV Pedestal	_____ 
TV Tower	_____ 
U/G TV Cable Hand Hole	_____ 
Recorded U/G TV Cable	_____ 
Designated U/G TV Cable (S.U.E.*)	_____ 
Recorded U/G Fiber Optic Cable	_____ 
Designated U/G Fiber Optic Cable (S.U.E.*)	_____ 



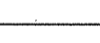
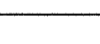





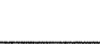
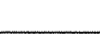

### GAS:

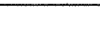
Gas Valve	_____ 
Gas Meter	_____ 
Recorded U/G Gas Line	_____ 
Designated U/G Gas Line (S.U.E.*)	_____ 
Above Ground Gas Line	_____ 

### SANITARY SEWER:

Sanitary Sewer Manhole	_____ 
Sanitary Sewer Cleanout	_____ 
U/G Sanitary Sewer Line	_____ 
Above Ground Sanitary Sewer	_____ 
Recorded SS Forced Main Line	_____ 
Designated SS Forced Main Line (S.U.E.*)	_____ 

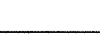
### MISCELLANEOUS:

Utility Pole	_____ 
Utility Pole with Base	_____ 
Utility Located Object	_____ 
Utility Traffic Signal Box	_____ 
Utility Unknown U/G Line	_____ 
U/G Tank; Water, Gas, Oil	_____ 
Underground Storage Tank, Approx. Loc.	_____ 
A/G Tank; Water, Gas, Oil	_____ 
Geoenvironmental Boring	_____ 
U/G Test Hole (S.U.E.*)	_____ 
Abandoned According to Utility Records	_____ 
End of Information	_____ 



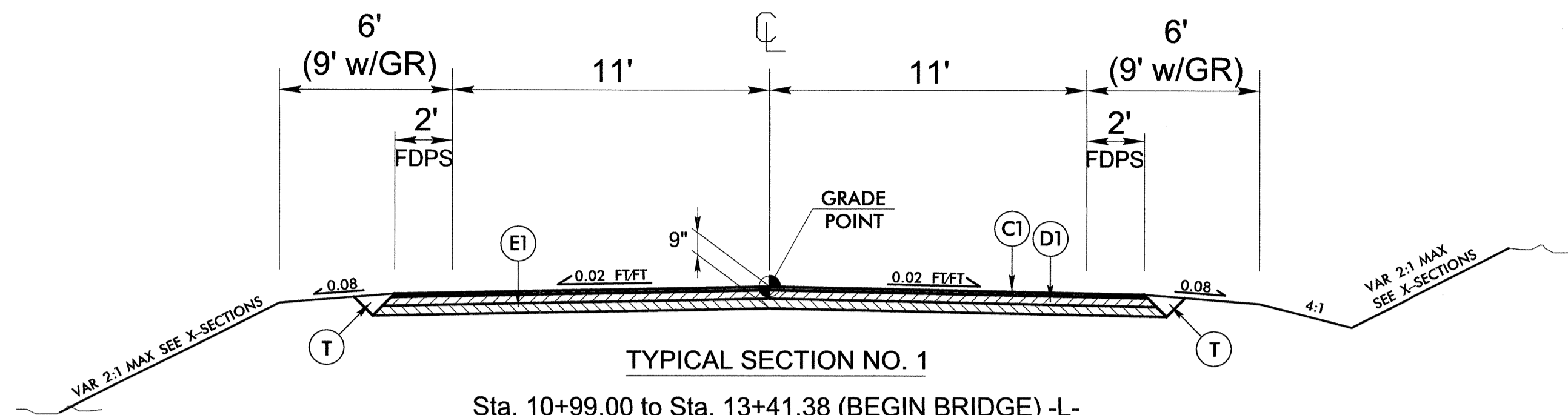

**TYPICAL SECTION NO. 1**  
 Sta. 10+99.00 to Sta. 13+41.38 (BEGIN BRIDGE) -L-  
 Sta. 13+98.63 (END BRIDGE) to Sta. 16+56.38 (BEGIN BRIDGE) -L-  
 Sta. 16+93.63 (END BRIDGE) to Sta. 20+73.87 (BEGIN BRIDGE) -L-  
 Sta. 21+16.12 (END BRIDGE) to Sta. 23+03.00 -L-

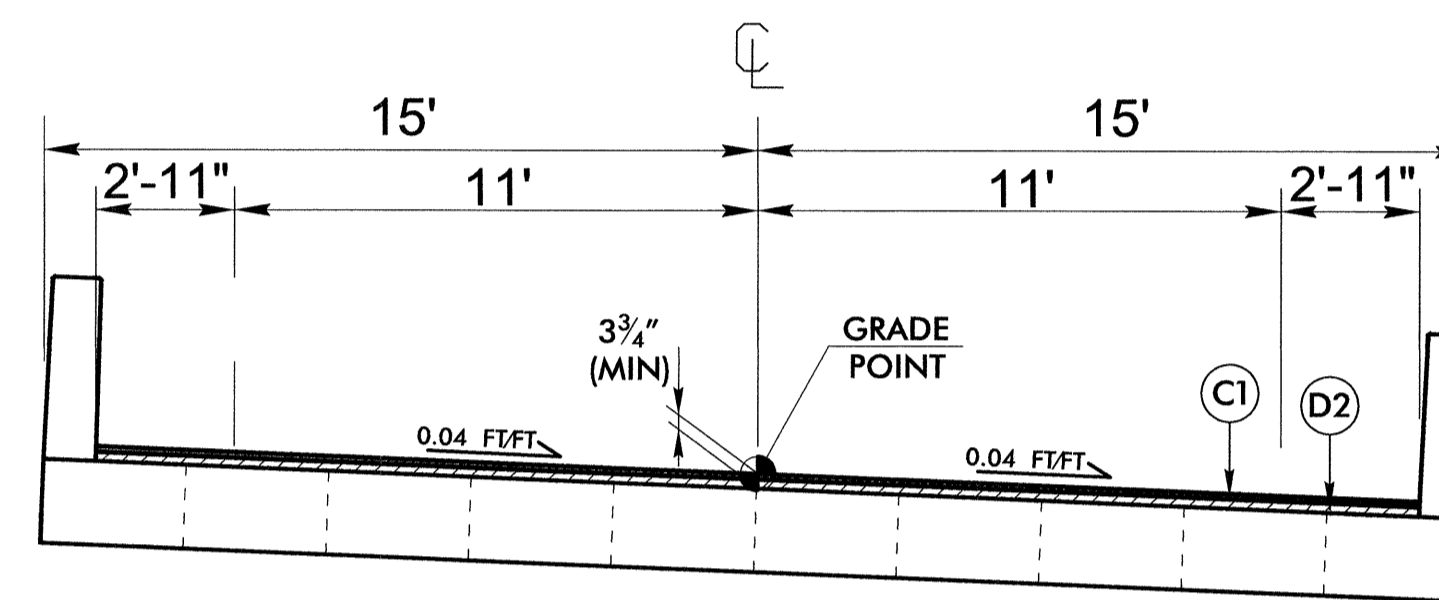

**TYPICAL SECTION NO. 2**  
 Sta. 13+41.38 (BEGIN BRIDGE) to Sta. 13+98.63 (END BRIDGE) -L-  
 SEE SHEET S-4 FOR 17.BP.5.R.27 DETAIL

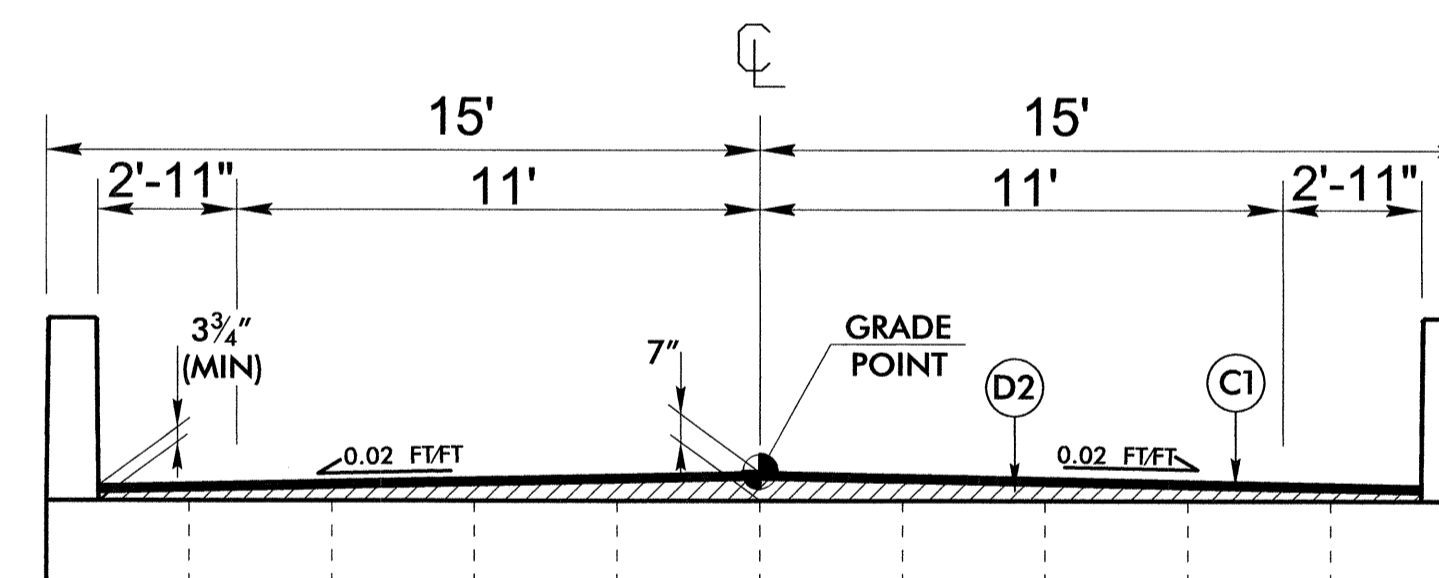

**TYPICAL SECTION NO. 3**  
 Sta. 16+56.38 (BEGIN BRIDGE) to Sta. 16+93.63 (END BRIDGE) -L-  
 SEE SHEET S-4 FOR 17.BP.5.R.25 DETAIL  
 Sta. 20+73.87 (BEGIN BRIDGE) to Sta. 21+16.12 (END BRIDGE) -L-  
 SEE SHEET S-4 FOR 17.BP.5.R.26 DETAIL

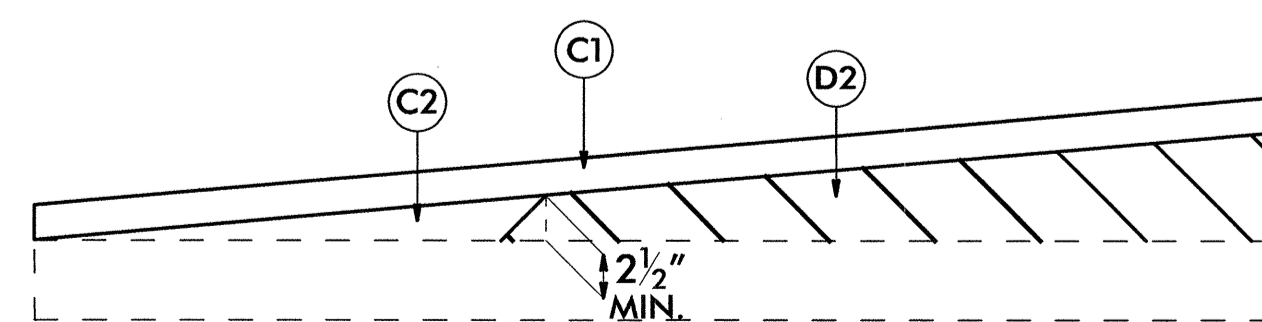
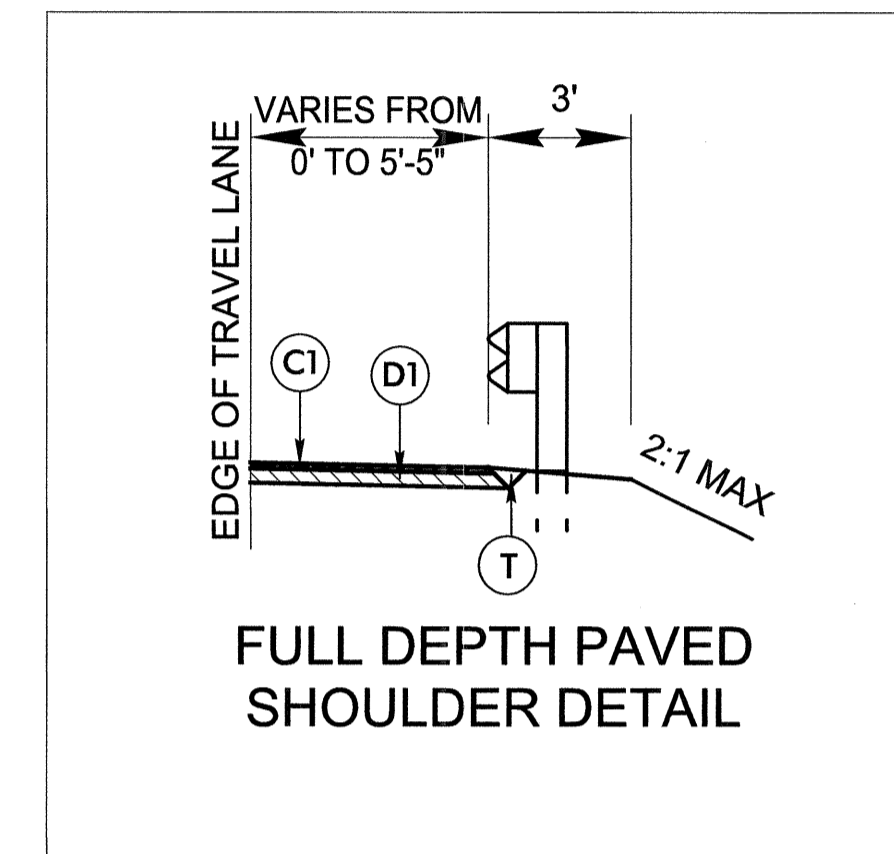

Wedging Detail For Asphalt on Bridge

**PAVEMENT SCHEDULE**

CODE	DESCRIPTION
C1	PROP. APPROX. 1.5" ASPHALT CONCRETE SURFACE COURSE, TYPE SF9.5A, AT AN AVERAGE RATE OF 165 LBS. PER SQ. YD.
C2	PROP. VAR. DEPTH ASPHALT CONCRETE SURFACE COURSE, TYPE SF9.5A, AT AN AVERAGE RATE OF 110 LBS. PER SQ. YD. PER 1" DEPTH TO BE PLACED IN LAYERS NOT TO EXCEED 1 1/2" DEPTH.
D1	PROP. APPROX. 3.5" ASPHALT CONCRETE INTERMEDIATE COURSE, TYPE I19.0B, AT AN AVERAGE RATE OF 399 LBS. PER SQ. YD.
D2	PROP. VAR. DEPTH ASPHALT CONCRETE INTERMEDIATE COURSE, TYPE I19.0B, AT AN AVERAGE RATE OF 114 LBS. PER SQ. YD. PER 1" DEPTH TO BE PLACED IN LAYERS NOT LESS THAN 2 1/2" AND NOT TO EXCEED 4" IN DEPTH.
E1	PROP. APPROX. 4" ASPHALT CONCRETE BASE COURSE, TYPE B25.0B, AT AN AVERAGE RATE OF 456 LBS. PER SQ. YD.
T	EARTH MATERIAL

Note: Pavement edge slopes are 1:1 unless shown otherwise





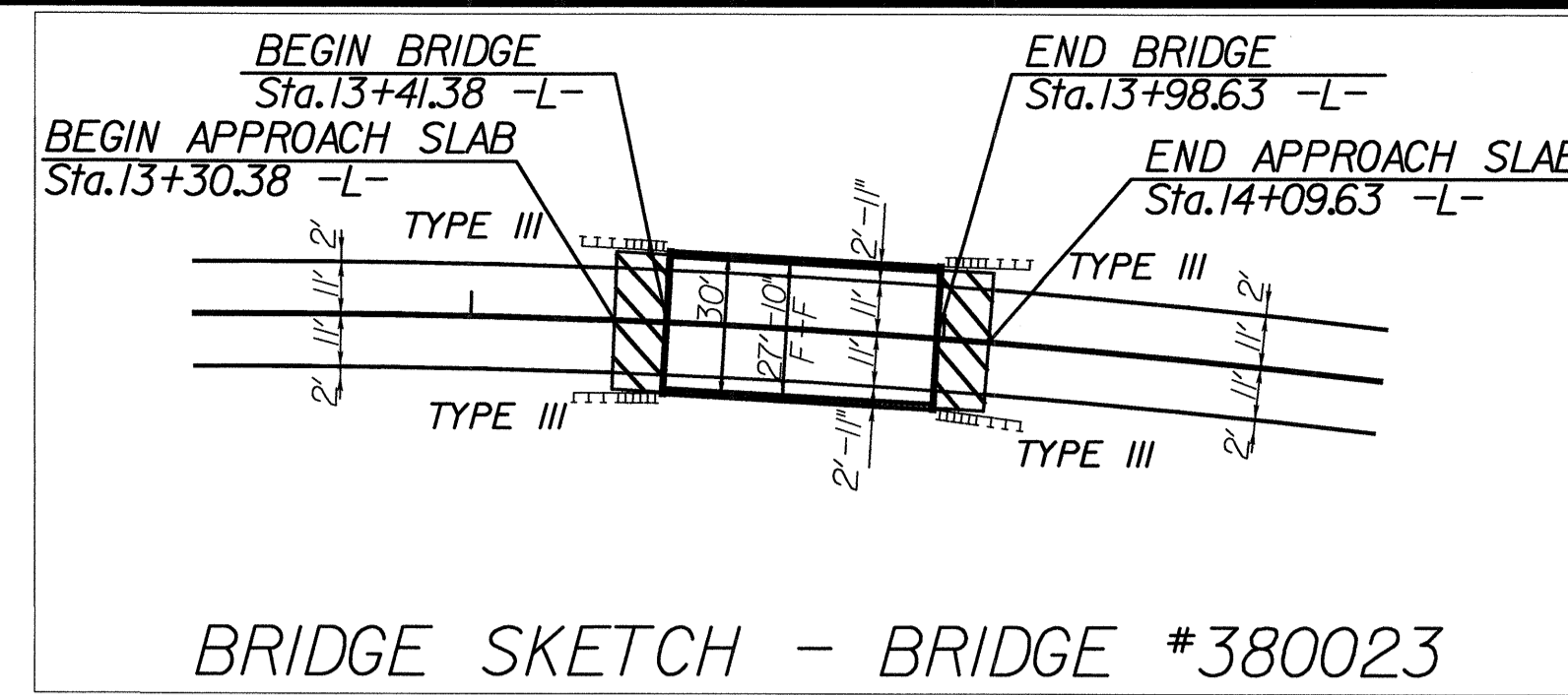

-L-  
PI Sta 13+87.44  
 $\Delta = 12' 50' 43.8''$  (RT)  
 $D = 2' 51' 53.2''$   
 $L = 448.39'$   
 $T = 225.14'$   
 $R = 2,000.00'$

REMOVE EXISTING ABUTMENTS AND FOOTINGS.  
PLACE BANK STABILIZATION W/CLASS II RIP RAP (SEE DETAIL 2).  
USE IMPERVIOUS DIKE STANDARD BMP ALONG STREAM BANKS TO DEWATER AND ISOLATE ADJACENT WORK AREA TO REMOVE EXISTING ABUTMENT AND PILES IN THE DRY. THE PLACEMENT OF THE IMPERVIOUS DIKE IS CONSIDERED INCIDENTAL TO THE ABUTMENT REMOVAL.

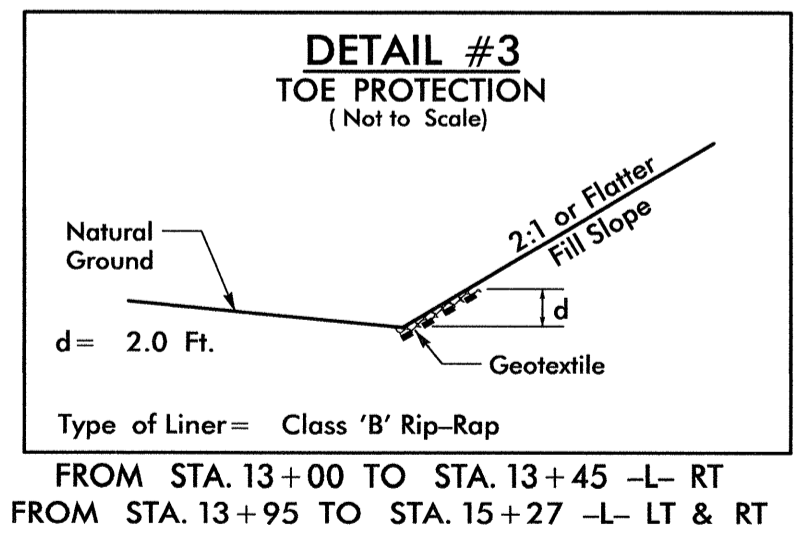
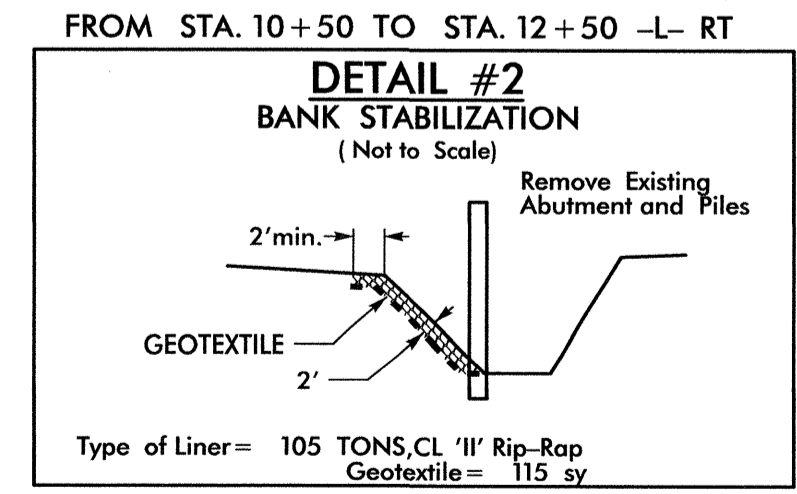
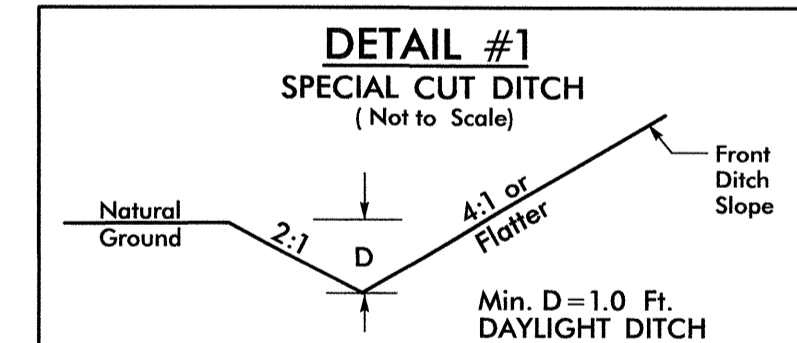
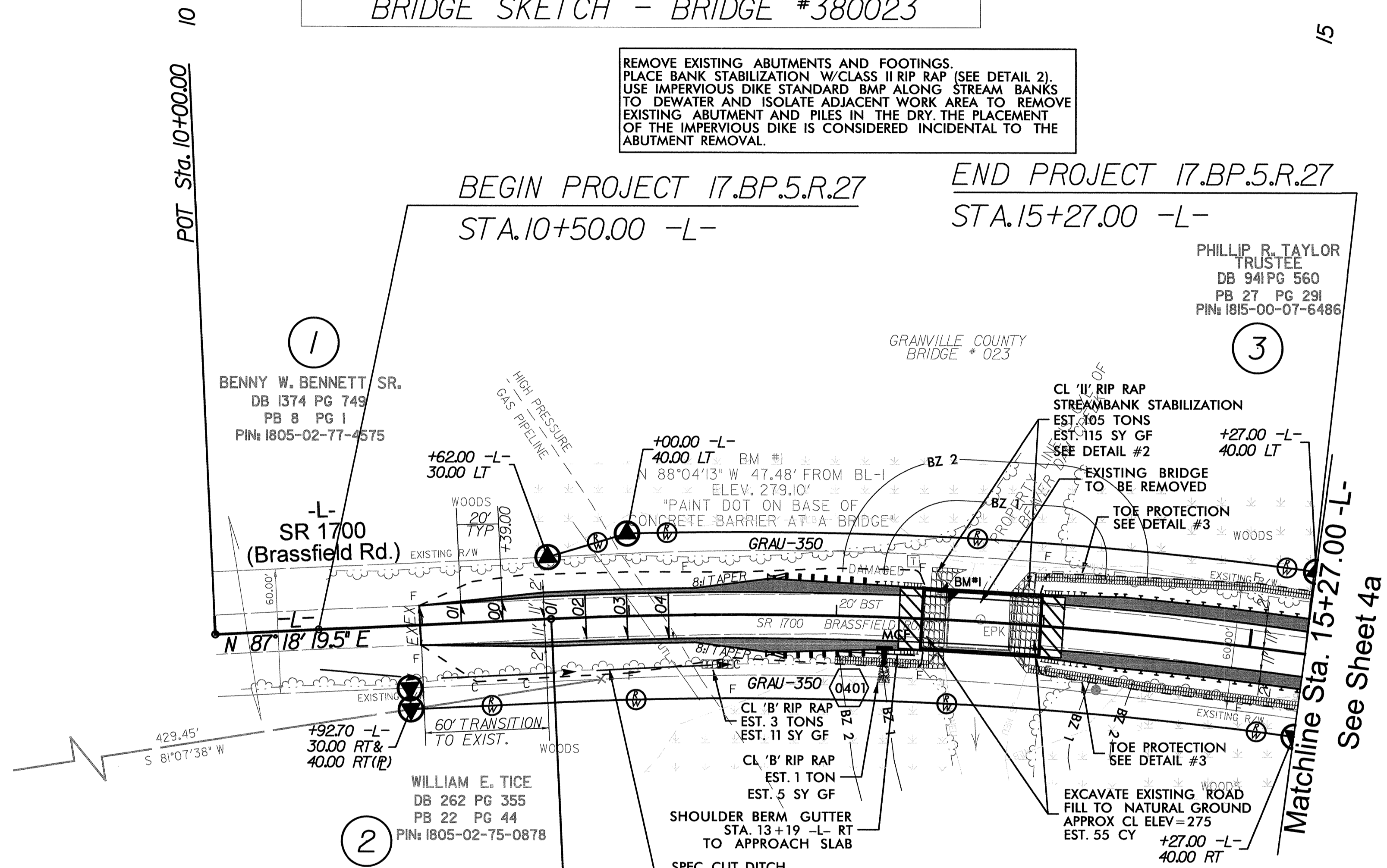

**DATUM DESCRIPTION**

THE LOCALIZED COORDINATE SYSTEM DEVELOPED FOR THIS PROJECT IS BASED ON THE STATE PLANE COORDINATES ESTABLISHED BY CH ENGINEERING FOR MONUMENT "BL-4" WITH NAD 83/NSRS 2007 STATE PLANE GRID COORDINATES OF NORTHING: 856978.188(ft) EASTING: 2109606.480(ft) ELEVATION: 282.693' (BL-1) THE AVERAGE COMBINED GRID FACTOR USED ON THIS PROJECT (GROUND TO GRID) IS: 0.99997465 THE N.C. LAMBERT GRID BEARING AND LOCALIZED HORIZONTAL GROUND DISTANCE FROM "BL-4" TO -L- STATION IS

ALL LINEAR DIMENSIONS ARE LOCALIZED HORIZONTAL DISTANCES VERTICAL DATUM USED IS NAVD 88

BM-1: PAINT DOT ON BASE OF CONCRETE BARRIER, 13.14' LT. OF STA. 13+53.13 -L-, EL. 279.10

DESC.	NORTHING	EASTING	ELEVATION
BL-1	857129.47	2108658.70	278.01
BL-2	857059.83	2108952.95	277.31
BL-3	856994.90	2109315.64	277.10
BL-4	856978.19	2109606.48	282.69

**PARCEL INDEX**

PARCEL NO.	PROPERTY OWNER NAME
1	BENNY W. BENNETT SR.
2	WILLIAM E. TICE
3	PHILLIP R. TAYLOR, TRUSTEE
4	THOMAS S. & DEBRA A. SAUNDERS

**-L- COORDINATE LIST**

STATION	NORTHING	EASTING
10+00	857110.45	2108257.74
11+00	857105.47	2108756.92
12+00	857020.37	2109249.58
13+00	857119.81	2108557.52
14+00	857115.13	2108657.40
15+00	857105.47	2108756.92
16+00	857090.84	2108855.83
17+00	857073.24	2108954.27
18+00	857055.62	2109052.71
19+00	857038.00	2109151.14
20+00	857020.37	2109249.58
21+00	857002.75	2109348.01
22+00	856985.12	2109446.45
23+00	856967.50	2109544.88
24+00	856949.88	2109643.32

SEE SHEET 1-B FOR MODIFIED CONCRETE FLUME DETAIL  
SEE SHEET 5 FOR -L- PROFILE

5/14/09  
2/1/2013  
17BP5R26.rdw\_psh04.dgn  
17/1/2013

NAD 83/NSRS 2007

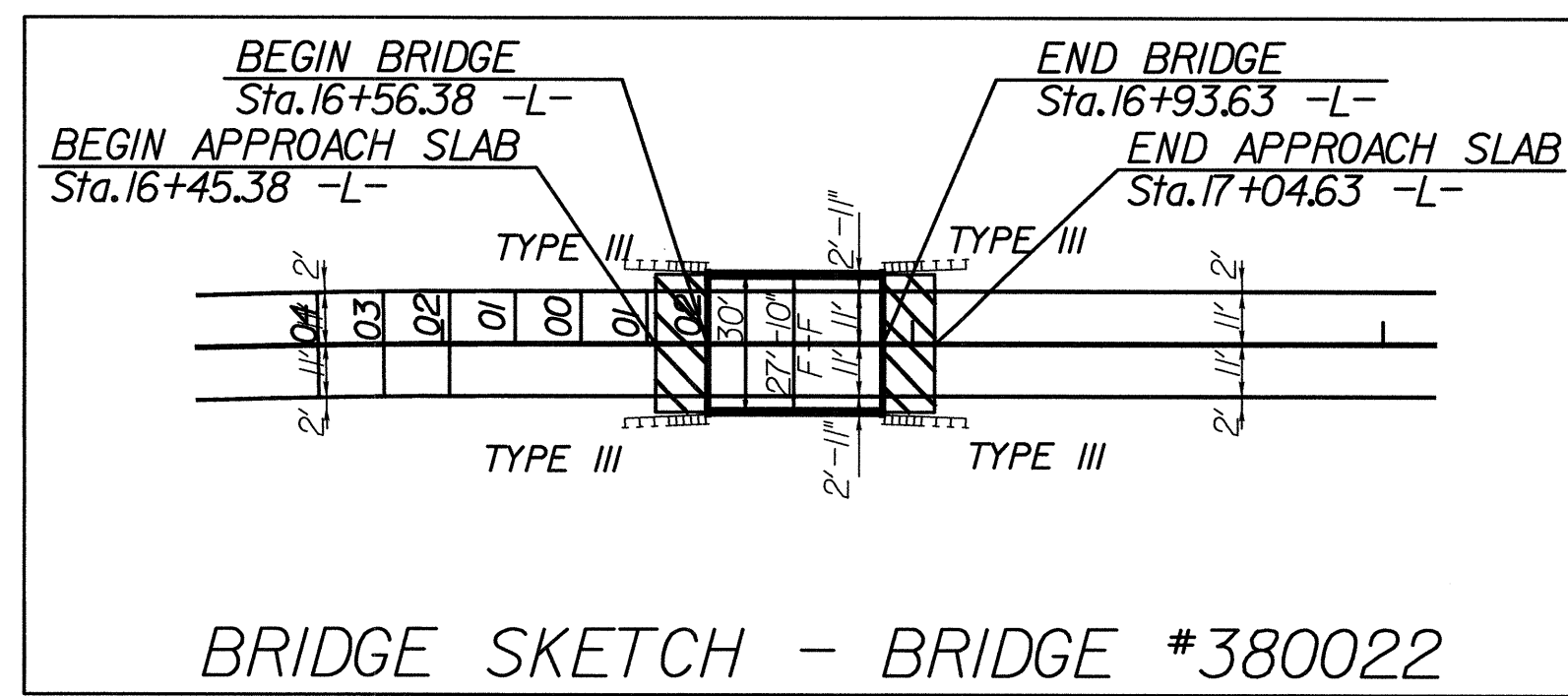

REMOVE EXISTING ABUTMENTS AND FOOTINGS. PLACE BANK STABILIZATION W/CLASS II RIP RAP (SEE DETAIL 2). USE IMPERVIOUS DIKE STANDARD BMP ALONG STREAM BANKS TO DEWATER AND ISOLATE ADJACENT WORK AREA TO REMOVE EXISTING ABUTMENT AND PILES IN THE DRY. THE PLACEMENT OF THE IMPERVIOUS DIKE IS CONSIDERED INCIDENTAL TO THE ABUTMENT REMOVAL.

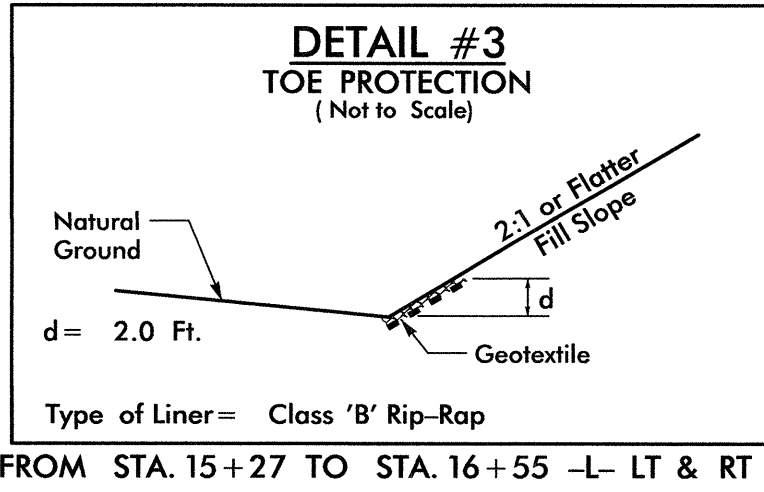
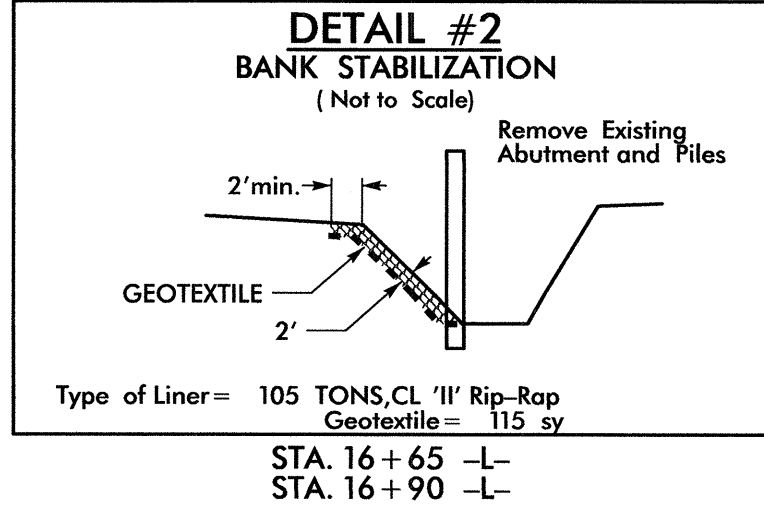
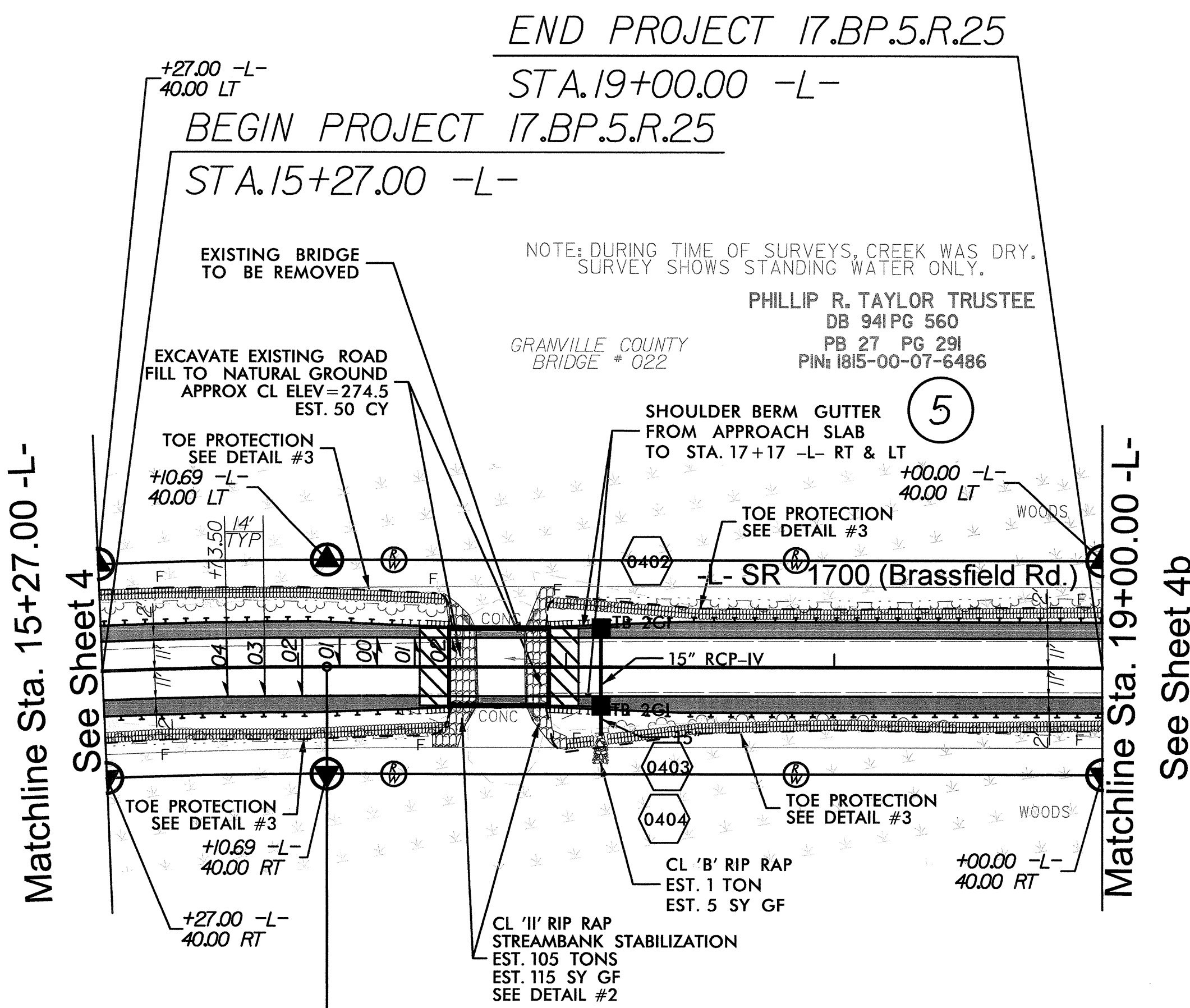

**DATUM DESCRIPTION**  
 THE LOCALIZED COORDINATE SYSTEM DEVELOPED FOR THIS PROJECT IS BASED ON THE STATE PLANE COORDINATES ESTABLISHED BY CH ENGINEERING FOR MONUMENT "BL-4" WITH NAD 83/NSRS 2007 STATE PLANE GRID COORDINATES OF NORTHING: 856978.188(±) EASTING: 2109606.480(±) ELEVATION: 282.693' (BL-1)  
 THE AVERAGE COMBINED GRID FACTOR USED ON THIS PROJECT (GROUND TO GRID) IS: 0.99997465  
 THE N.C. LAMBERT GRID BEARING AND LOCALIZED HORIZONTAL GROUND DISTANCE FROM "BL-4" TO -L- STATION IS  
 ALL LINEAR DIMENSIONS ARE LOCALIZED HORIZONTAL DISTANCES VERTICAL DATUM USED IS NAVD 88

BM-I: PAINT DOT ON BASE OF CONCRETE BARRIER, 13.14' LT. OF STA. 13+53.13 -L-, EL. 279.10

DESC.	NORTHING	EASTING	ELEVATION
BL-1	857129.47	2108658.70	278.01
BL-2	857059.83	2108952.95	277.31
BL-3	856994.90	2109315.64	277.10
BL-4	856978.19	2109606.48	282.69

(6)  
 THOMAS S & DEBRA A. SAUNDERS  
 DB 753 PG 481  
 PB 22 PG 44  
 PIN: 1805-02-96-2031

-L-  
 PI Sta 13+87.44  
 $\Delta = 12' 50' 43.8" (RT)$   
 $D = 2' 51' 53.2"$   
 $L = 448.39'$   
 $T = 225.14'$   
 $R = 2,000.00'$

**PARCEL INDEX**

PARCEL NO.	PROPERTY OWNER NAME
5	PHILLIP R. TAYLOR, TRUSTEE
6	THOMAS S. & DEBRA A. SAUNDERS

-L- COORDINATE LIST

STATION	NORTHING	EASTING
10+00	857110.45	2108257.74
11+00	857105.47	2108756.92
12+00	857020.37	2109249.58
13+00	857119.81	2108557.52
14+00	857115.13	2108657.40
15+00	857105.47	2108756.92
16+00	857090.84	2108855.83
17+00	857073.24	2108954.27
18+00	857055.62	2109052.71
19+00	857038.00	2109151.14
20+00	857020.37	2109249.58
21+00	857002.75	2109348.01
22+00	856985.12	2109446.45
23+00	856967.50	2109544.88
24+00	856949.88	2109643.32

SEE SHEET 5 FOR -L- PROFILE

NAD 83/NSRS 2007

5/14/99  
2/1/03  
17.BP.5.R.25.r.dwg-psn04a.dgn



20

REMOVE EXISTING ABUTMENTS AND FOOTINGS.  
PLACE BANK STABILIZATION W/CLASS II RIP RAP (SEE DETAIL 2).  
USE IMPERVIOUS DIKE STANDARD BMP ALONG STREAM BANKS  
TO DEWATER AND ISOLATE ADJACENT WORK AREA TO REMOVE  
EXISTING ABUTMENT AND PILES IN THE DRY. THE PLACEMENT  
OF THE IMPERVIOUS DIKE IS CONSIDERED INCIDENTAL TO THE  
ABUTMENT REMOVAL.

7

PHILLIP R. TAYLOR TRUSTEE  
DB 941 PG 560  
PB 27 PG 291  
PIN: 1815-00-07-6486

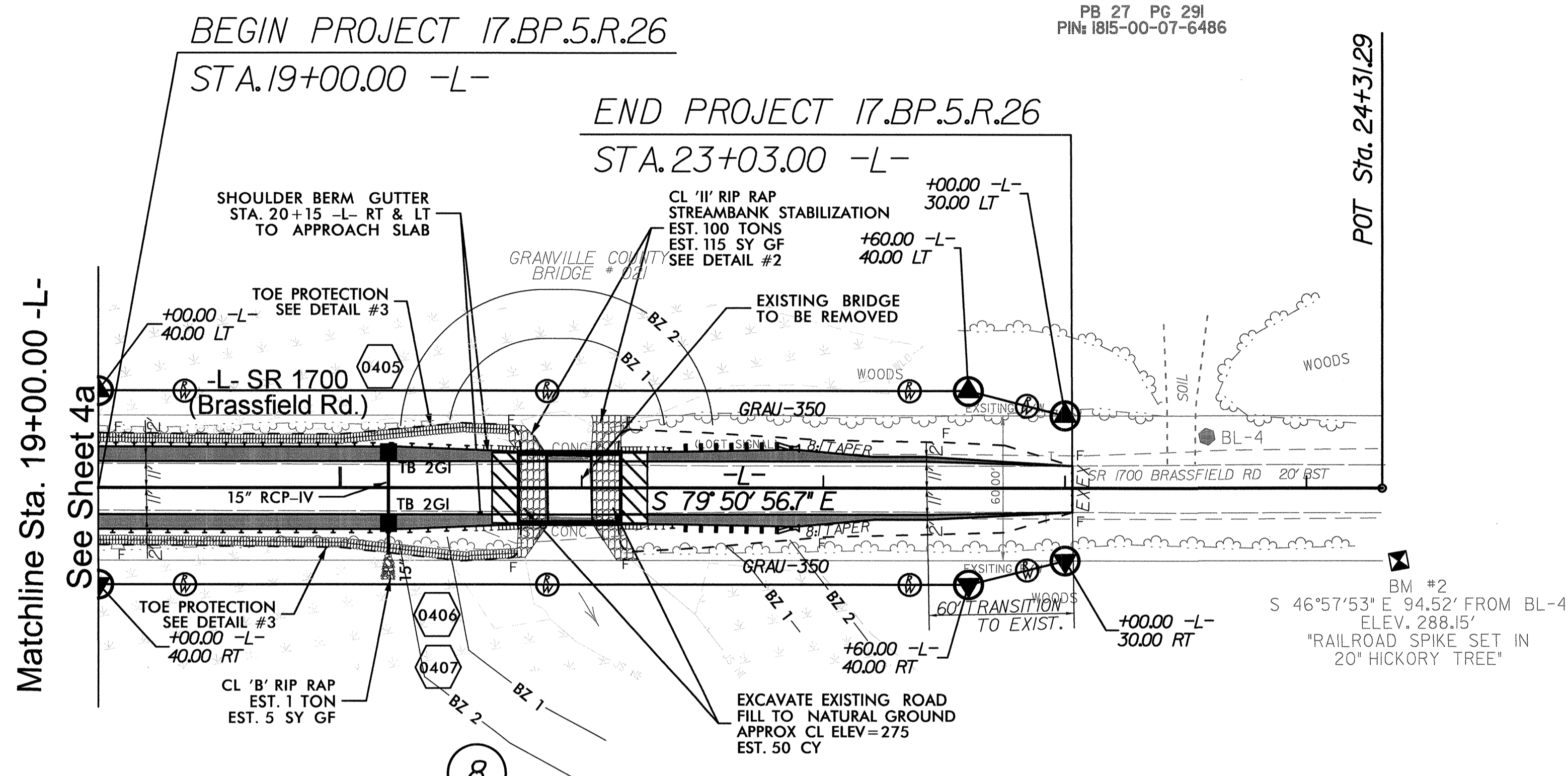

NAD 83/NSRS 2007

8

THOMAS S & DEBRA A. SAUNDERS  
DB 753 PG 481  
PB 22 PG 44  
PIN: 1805-02-96-2031

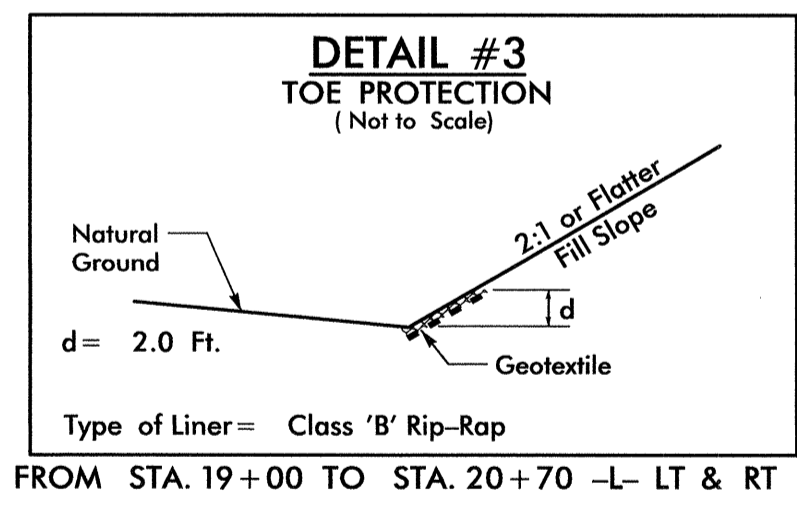
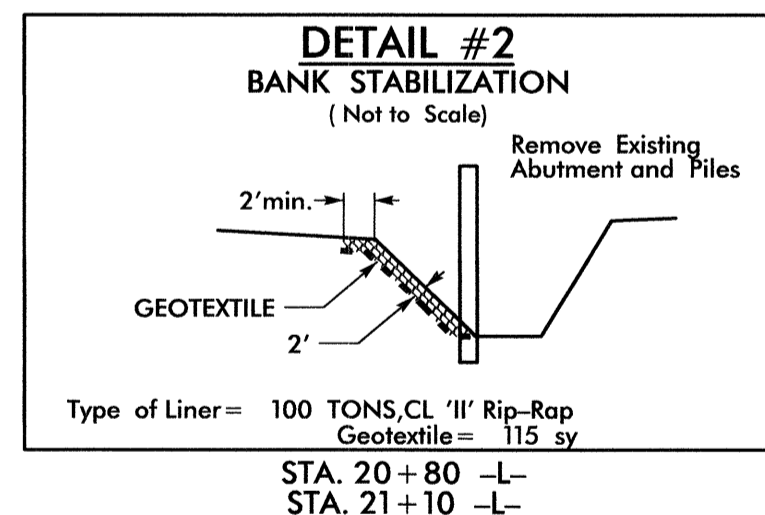

**DATUM DESCRIPTION**  
THE LOCALIZED COORDINATE SYSTEM DEVELOPED FOR THIS PROJECT IS BASED ON THE STATE PLANE COORDINATES ESTABLISHED BY CH ENGINEERING FOR MONUMENT "BL-4" WITH NAD 83/NSRS 2007 STATE PLANE GRID COORDINATES OF NORTHING: 856978.188(±) EASTING: 2109606.480(±) ELEVATION: 282.693' (BL-1)  
THE AVERAGE COMBINED GRID FACTOR USED ON THIS PROJECT (GROUND TO GRID) IS: 0.99997465  
THE N.C. LAMBERT GRID BEARING AND LOCALIZED HORIZONTAL GROUND DISTANCE FROM "BL-4" TO -L- STATION IS

DESC.	NORTHING	EASTING	ELEVATION
BL-1	857129.47	2108658.70	278.01
BL-2	857059.83	2108952.95	277.31
BL-3	856994.90	2109315.64	277.10
BL-4	856978.19	2109606.48	282.69

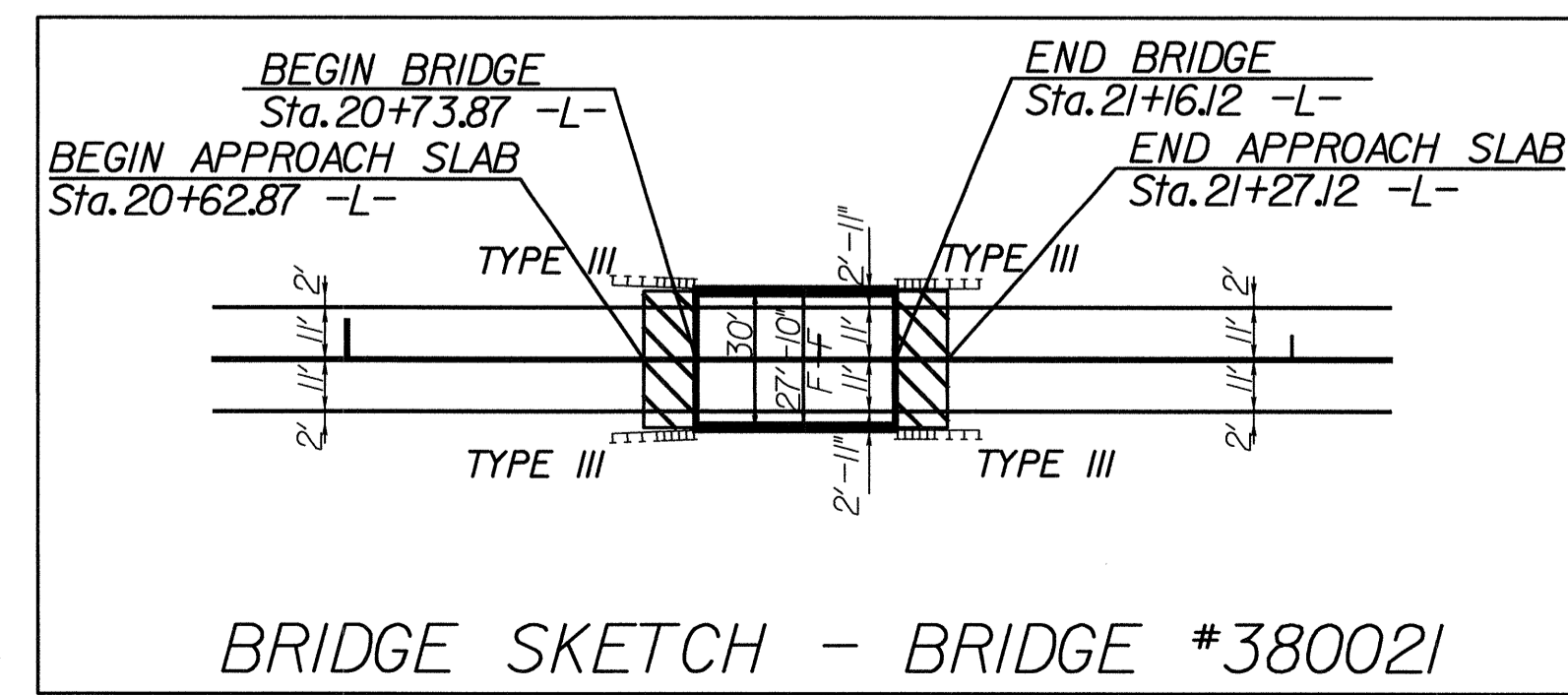

PARCEL INDEX	
PARCEL NO.	PROPERTY OWNER NAME
7	PHILLIP R. TAYLOR, TRUSTEE
8	THOMAS S. & DEBRA A. SAUNDERS

-L- COORDINATE LIST		
STATION	NORTHING	EASTING
10+00	857110.45	2108257.74
11+00	857105.47	2108756.92
12+00	857020.37	2109249.58
13+00	857119.81	2108557.52
14+00	857115.13	2108657.40
15+00	857105.47	2108756.92
16+00	857090.84	2108855.83
17+00	857073.24	2108954.27
18+00	857055.62	2109052.71
19+00	857038.00	2109151.14
20+00	857020.37	2109249.58
21+00	857002.75	2109348.01
22+00	856985.12	2109446.45
23+00	856967.50	2109544.88
24+00	856949.88	2109643.32

SEE SHEET 5 FOR -L- PROFILE

5/14/99

2/17/2013 17:58:26\_r-djy-ps104b.dgn



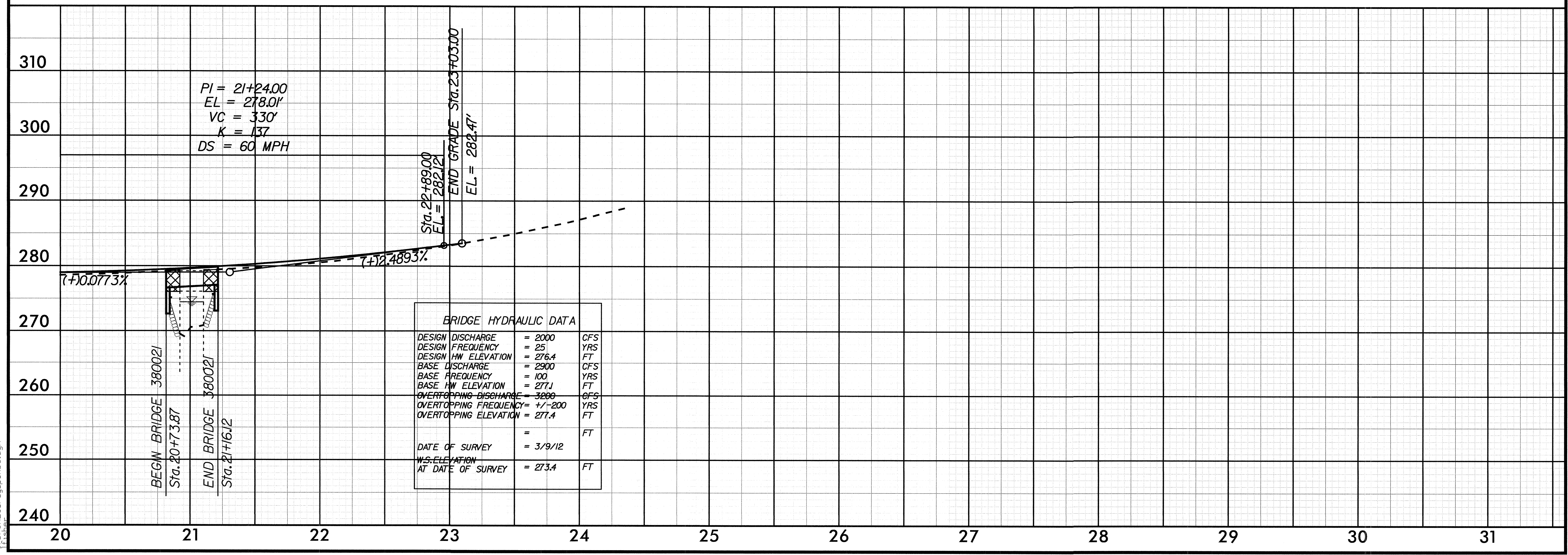
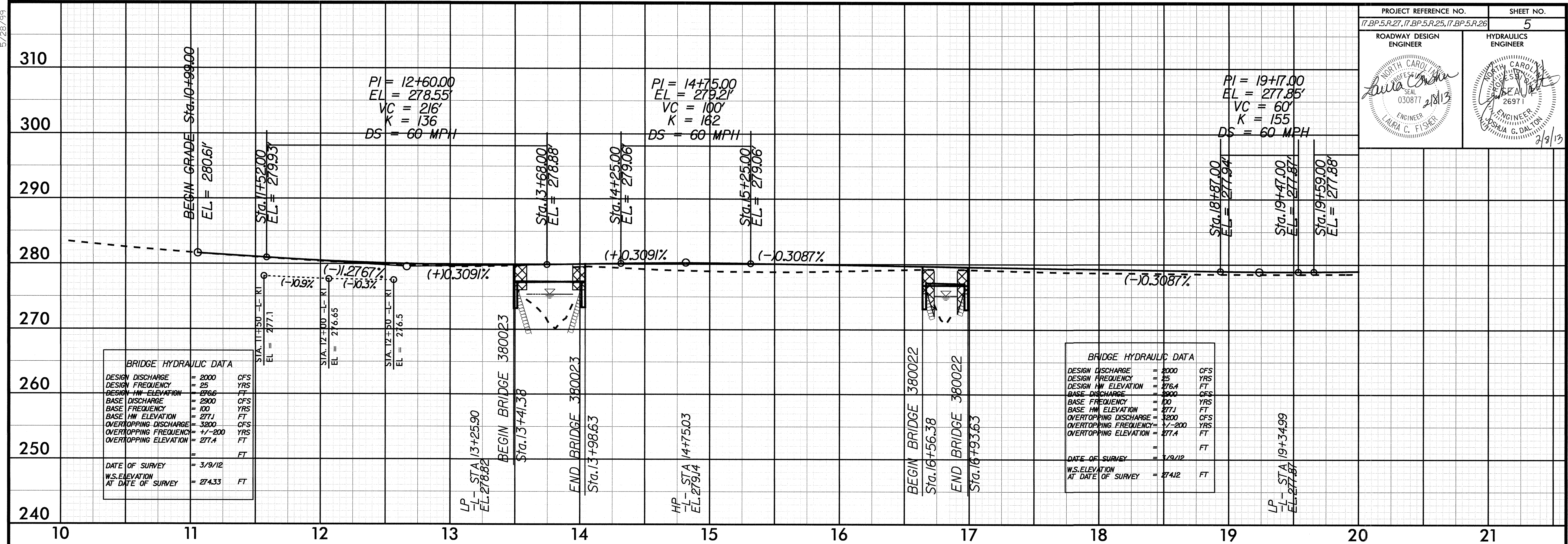

5/28/99

2/16/2013 11:46:26 AM rdu\_psh05.dgn



# PHASING AND PAVEMENT MARKING PLAN

PROJECT REFERENCE NO.	SHEET NO.
17.BP.5.R.27, 17.BP.5.R.25, 17.BP.5.R.26	TCP-1
R/W SHEET NO.	

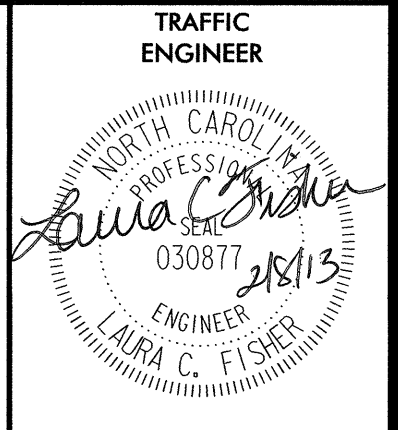

## GENERAL NOTES

CHANGES MAY BE REQUIRED WHEN PHYSICAL DIMENSIONS IN THE DETAIL DRAWINGS, STANDARD DETAILS, AND ROADWAY DETAILS ARE NOT ATTAINABLE TO MEET FIELD CONDITIONS OR RESULT IN DUPLICATE OR UNDESIRE OVERLAPPING OF DEVICES. MODIFICATION MAY INCLUDE: MOVING, SUPPLEMENTING, COVERING, OR REMOVAL OF DEVICES AS DIRECTED BY THE ENGINEER.

THE FOLLOWING GENERAL NOTES APPLY AT ALL TIMES FOR THE DURATION OF THE CONSTRUCTION PROJECT EXCEPT WHEN OTHERWISE NOTED IN THE PLAN OR DIRECTED BY THE ENGINEER.

### LANE AND SHOULDER CLOSURE REQUIREMENTS

A) WHEN PERSONNEL AND/OR EQUIPMENT ARE WORKING WITHIN 15 FT OF AN OPEN TRAVEL LANE, CLOSE THE NEAREST OPEN SHOULDER USING ROADWAY STANDARD DRAWING NO. 1101.04 UNLESS THE WORK AREA IS PROTECTED BY BARRIER OR GUARDRAIL OR A LANE CLOSURE IS INSTALLED.

### TRAFFIC PATTERN ALTERATIONS

B) NOTIFY THE ENGINEER THIRTY (30) CALENDAR DAYS PRIOR TO ANY TRAFFIC PATTERN ALTERATION.

### SIGNING

C) PROVIDE SIGNING AND DEVICES REQUIRED TO CLOSE THE ROAD ACCORDING TO THE ROADWAY STANDARD DRAWINGS AND TRAFFIC CONTROL PLANS.

PROVIDE SIGNING REQUIRED FOR THE OFF-SITE DETOUR ROUTE AS SHOWN IN THE TRAFFIC CONTROL PLANS.

D) COVER OR REMOVE ALL SIGNS AND DEVICES REQUIRED TO CLOSE THE ROAD WHEN ROAD CLOSURE IS NOT IN OPERATION.

COVER OR REMOVE ALL SIGNS REQUIRED FOR THE OFF-SITE DETOUR WHEN THE DETOUR IS NOT IN OPERATION.

E) ENSURE ALL NECESSARY SIGNING IS IN PLACE PRIOR TO ALTERING ANY TRAFFIC PATTERN.

### TRAFFIC CONTROL DEVICES

F) PLACE TYPE III BARRICADES, WITH "ROAD CLOSED" SIGN R11-2 ATTACHED, OF SUFFICIENT LENGTH TO CLOSE THE ENTIRE ROADWAY.

### PAVEMENT MARKINGS AND MARKERS

G) INSTALL PAVEMENT MARKINGS ON THE FINAL SURFACE ACCORDING TO THE ROADWAY STANDARD DRAWINGS.

H) INSTALL PAVEMENT MARKINGS ON THE FINAL SURFACE AS FOLLOWS:

ROAD NAME	MARKING
SR 1700 (BRASSFIELD ROAD)	PAINT

I) TIE PROPOSED PAVEMENT MARKING LINES TO EXISTING PAVEMENT MARKING LINES

### MISCELLANEOUS

J) MAINTAIN ACCESS TO ALL RESIDENCES AND BUSINESSES BETWEEN THE CLOSURE POINTS AT ALL TIMES DURING CONSTRUCTION.

## ROADWAY STANDARD DRAWINGS

THE FOLLOWING ROADWAY STANDARDS AS THEY APPEAR IN THE "ROADWAY STANDARD DRAWINGS" - ROADWAY DESIGN UNIT - N.C. DEPARTMENT OF TRANSPORTATION, DATED JANUARY 2012, ARE APPLICABLE TO THIS PROJECT AND BY REFERENCE HEREBY ARE CONSIDERED A PART OF THESE PLANS.

STD. NO.	TITLE
1101.03	TEMPORARY ROAD CLOSURES
1101.04	TEMPORARY SHOULDER CLOSURES
1110.02	PORTABLE WORK ZONE SIGNS
1145.01	BARRICADES
1205.01	PAVEMENT MARKINGS - LINE TYPES AND OFFSETS
1205.02	PAVEMENT MARKINGS - 2 LANE & MULTILANE ROADWAYS
1205.12	PAVEMENT MARKINGS - BRIDGES
1261.01	GUARDRAIL AND BARRIER DELINEATOR SPACING
1261.02	GUARDRAIL AND BARRIER DELINEATOR TYPES
1262.01	GUARDRAIL END DELINEATION

## PHASING

### STEP 1

USING ROADWAY STANDARD DRAWING NO. 1101.04, SHEET 1 OF 1, INSTALL ALL DETOUR SIGNING KEEPING SIGNS COVERED.

### STEP 2

USING ROADWAY STANDARD DRAWING NO. 1101.03, SHEET 1 OF 9, UNCOVER ALL DETOUR SIGNING, CLOSE SR 1700 (BRASSFIELD RD.) TO TRAFFIC AND SHIFT TRAFFIC TO DETOUR ROUTE.

### STEP 3

DISMANTLE AND REMOVE EXISTING BRIDGE.

### STEP 4

COMPLETE CONSTRUCTION OF PROPOSED STRUCTURES, APPROACH ROADWAY TIE-INS, AND ASSOCIATED ITEMS.

### STEP 5

PLACE FINAL PAVEMENT MARKINGS ON SR 1700 (BRASSFIELD RD.) AND OPEN TO TRAFFIC.

### STEP 6

USING ROADWAY STANDARD DRAWING NO. 1101.04, SHEET 1 OF 1, REMOVE ALL DETOUR SIGNING AND ALL TRAFFIC CONTROL DEVICES.

## FINAL PAVEMENT MARKING SCHEDULE

DESCRIPTION	PAY ITEM
WHITE EDGELINE (2X)	PAINT (4")
DOUBLE YELLOW CENTER LINE (2X)	PAINT (4")

PRELIMINARY PLANS  
DO NOT USE FOR CONSTRUCTION

# DETOUR FOR GRANVILLE 21, 22, and 23 BRIDGE CLOSURES

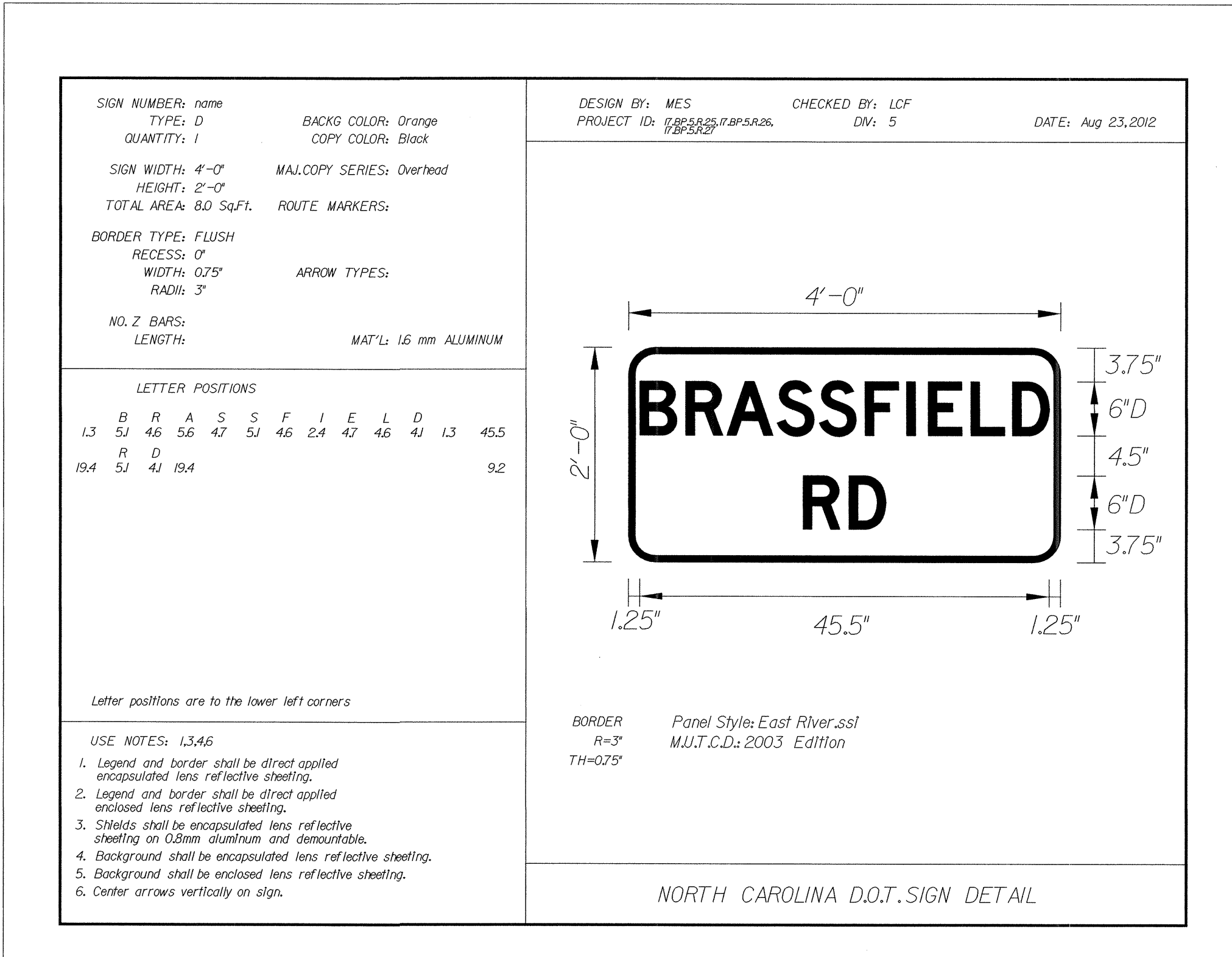
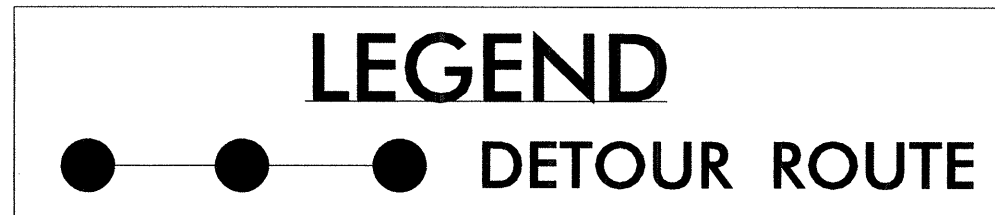
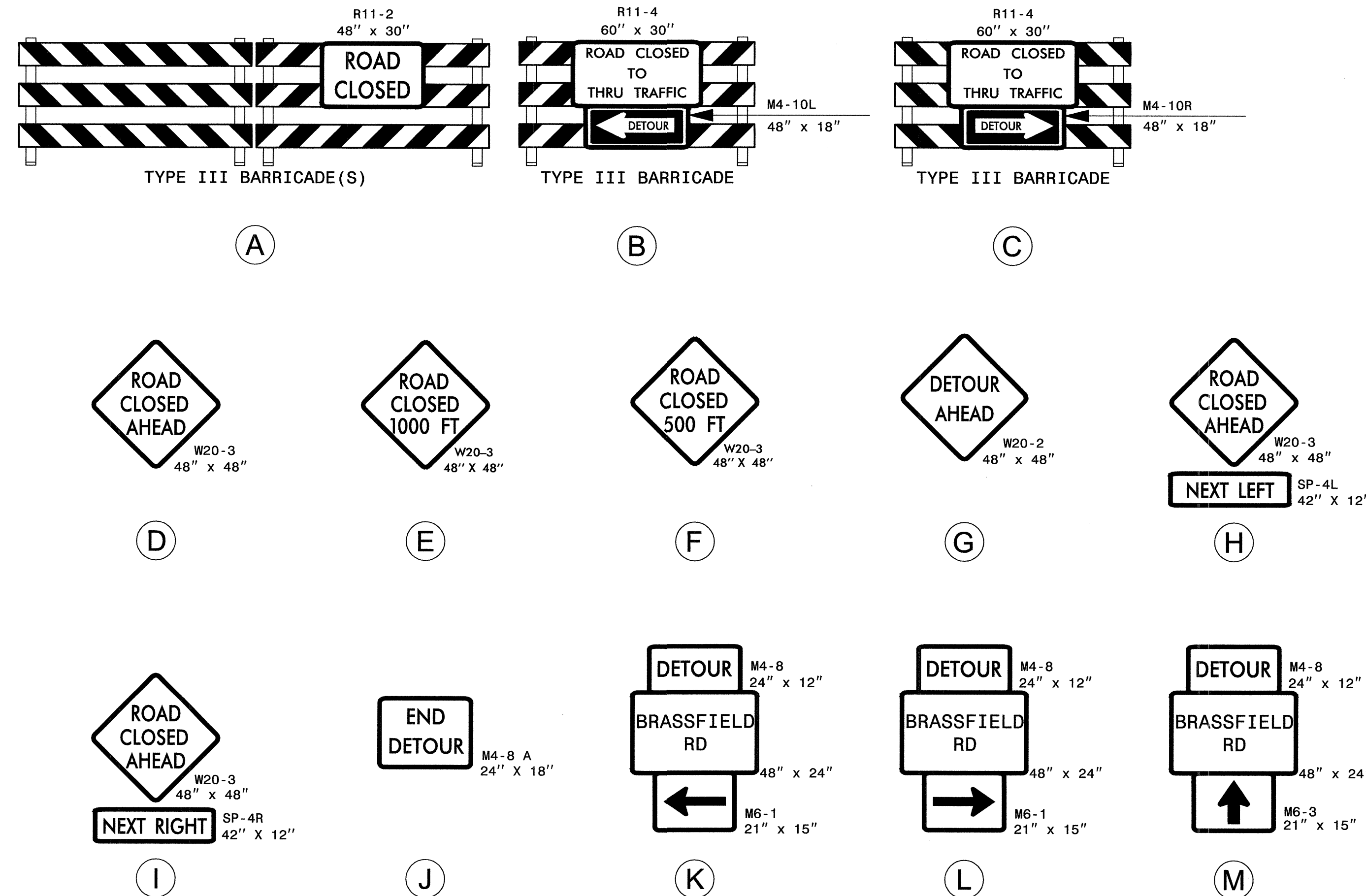
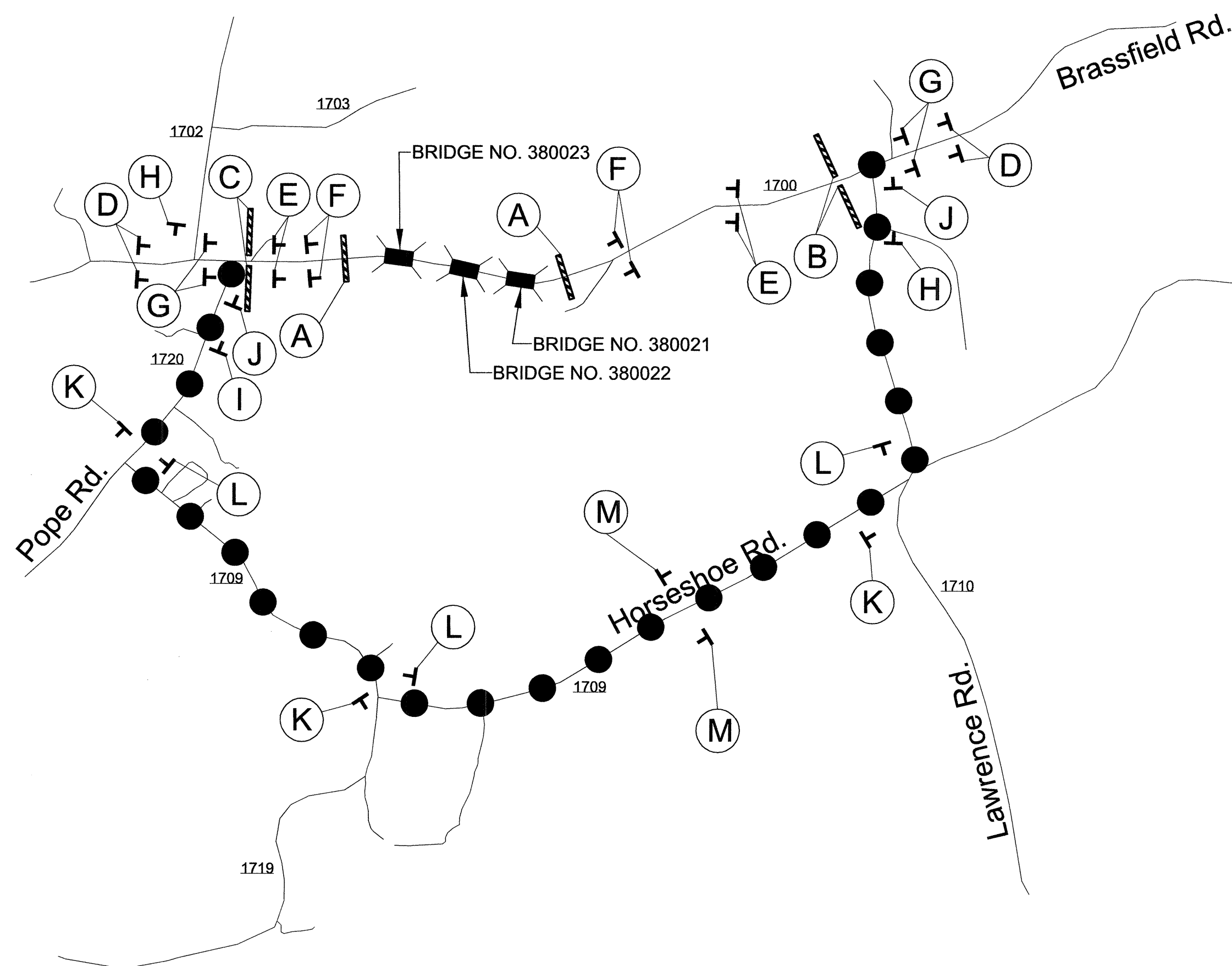
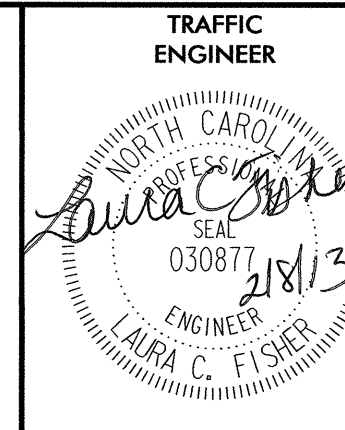



8/23/99



PROJ. REFERENCE NO.  
17.BP.5.R.27, 17.BP.5.R.25, 17.BP.5.R.26

SHEET NO.  
X-1

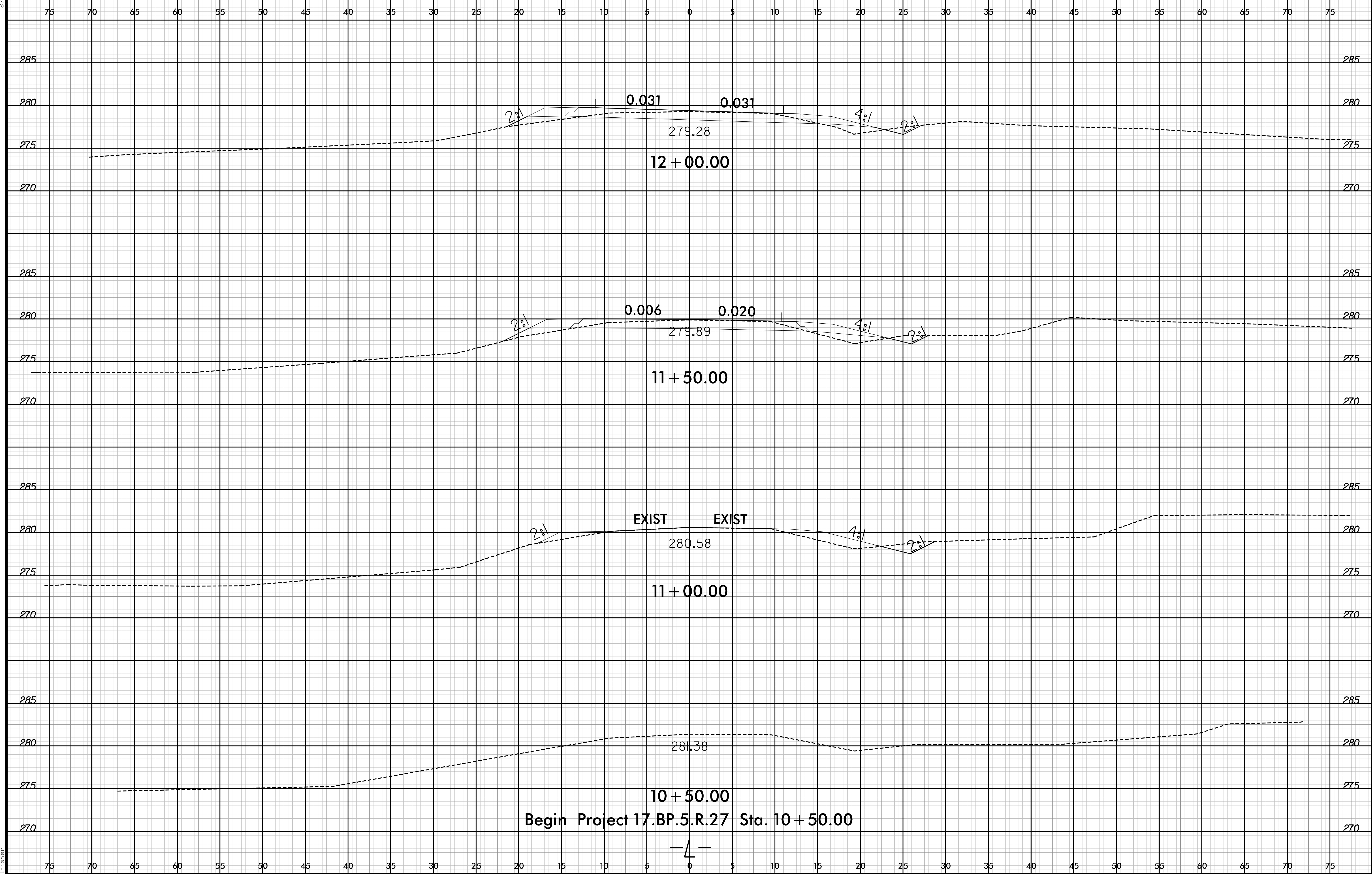

2/13/2013  
17.BP.5.R.26\_r.dwg\_xpl.dgn

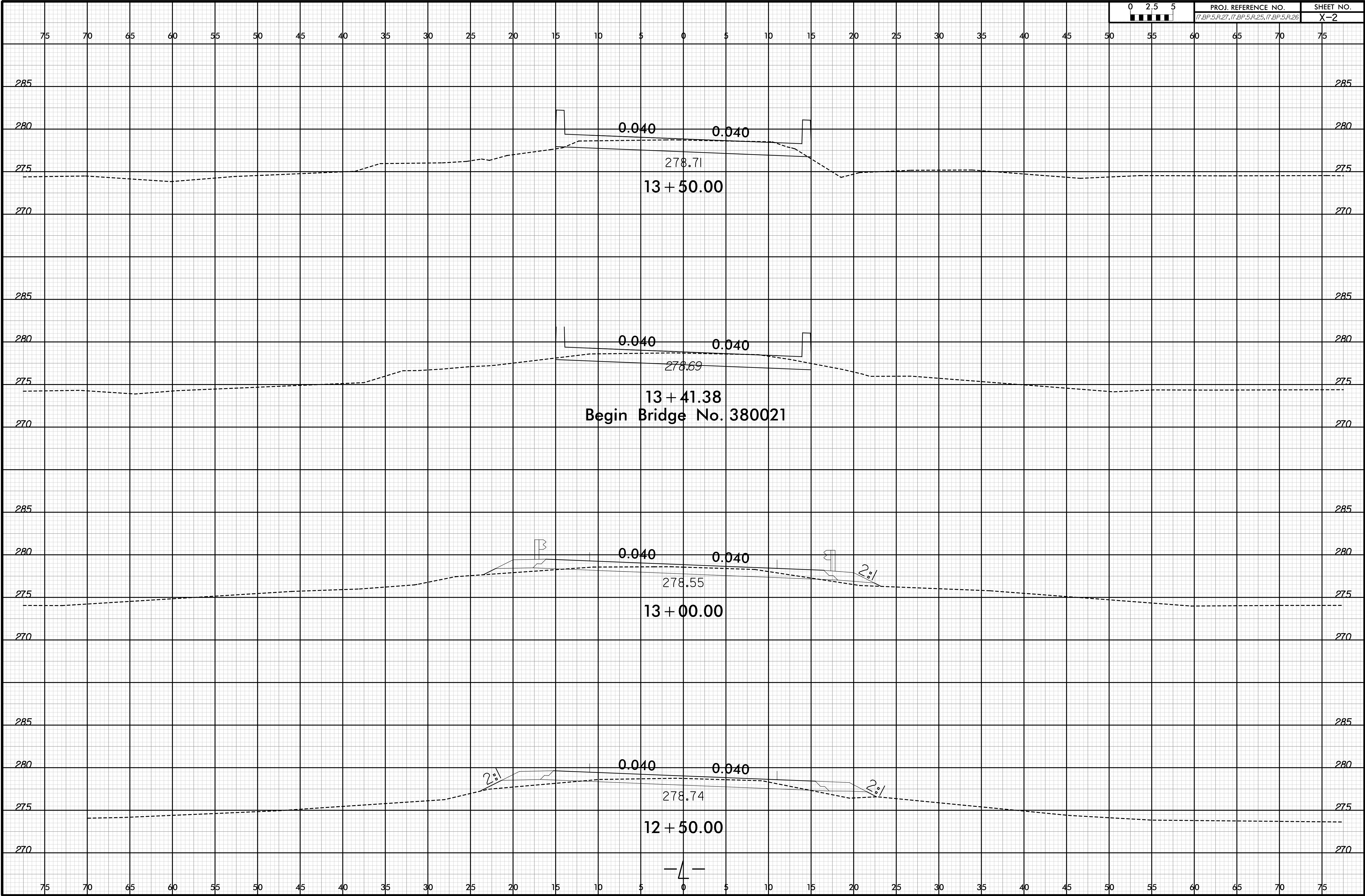



8/23/99



PROJ. REFERENCE NO.  
17.BP.5.R.27, 17.BP.5.R.25, 17.BP.5.R.26

SHEET NO.  
X-3

Begin Project 17.BP.5.R.25 Sta. 15 + 27.00  
End Project 17.BP.5.R.27 Sta. 15 + 27.00

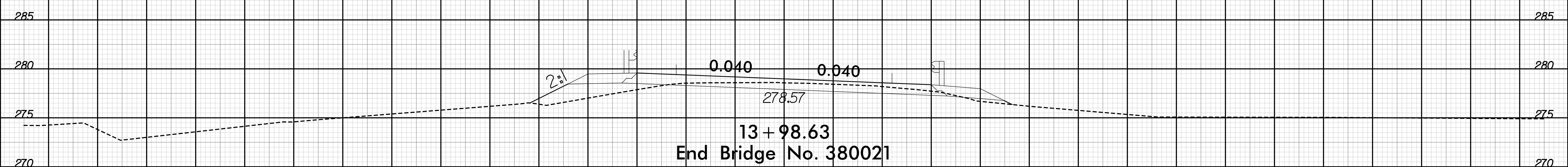
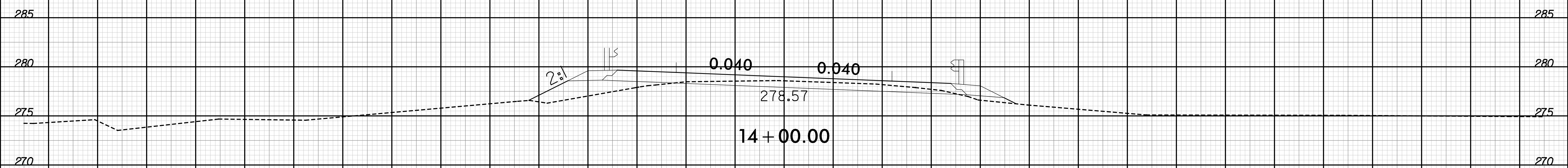
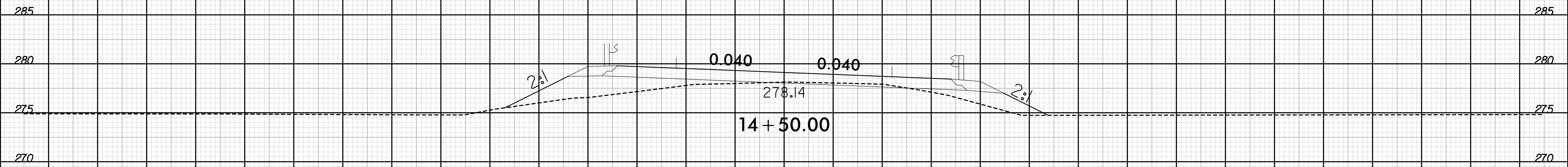
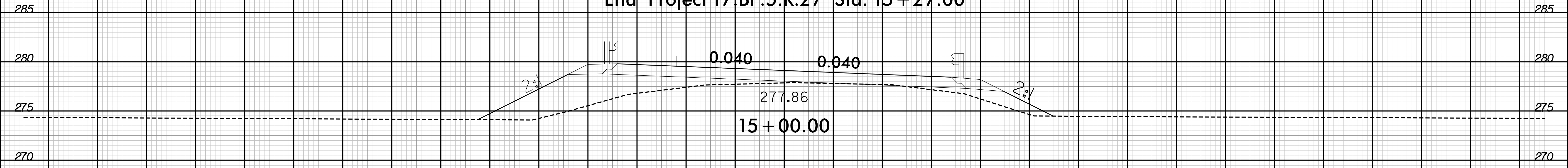

End Bridge No. 380021

2/13/2013  
17.BP.5.R.26-r.dwg-xpl.dgn

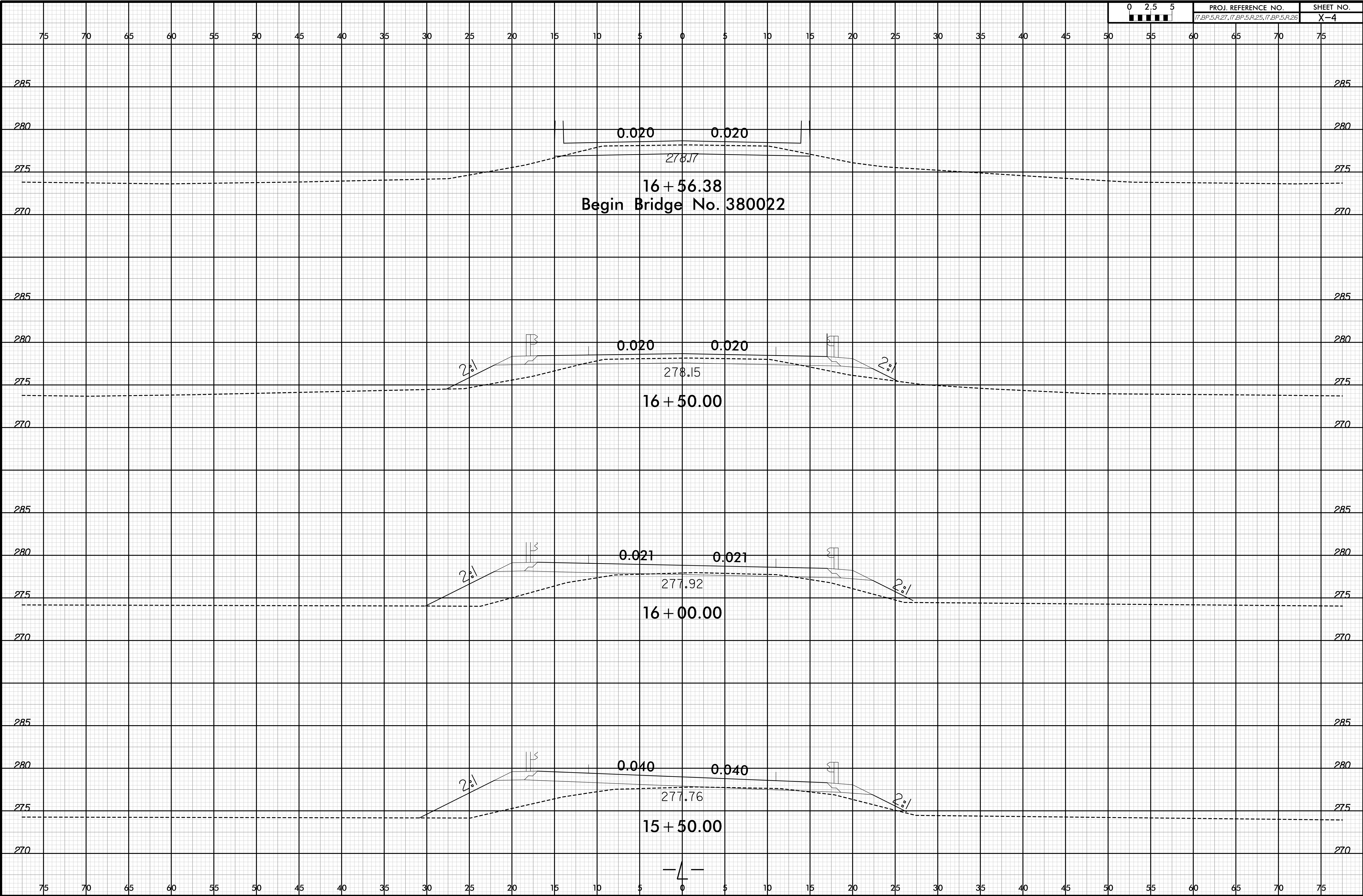



8/23/99

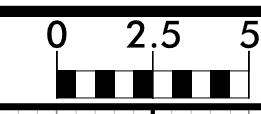

PROJ. REFERENCE NO.	SHEET NO.
17.BP.5.R.27, 17.BP.5.R.25, 17.BP.5.R.26	X-5

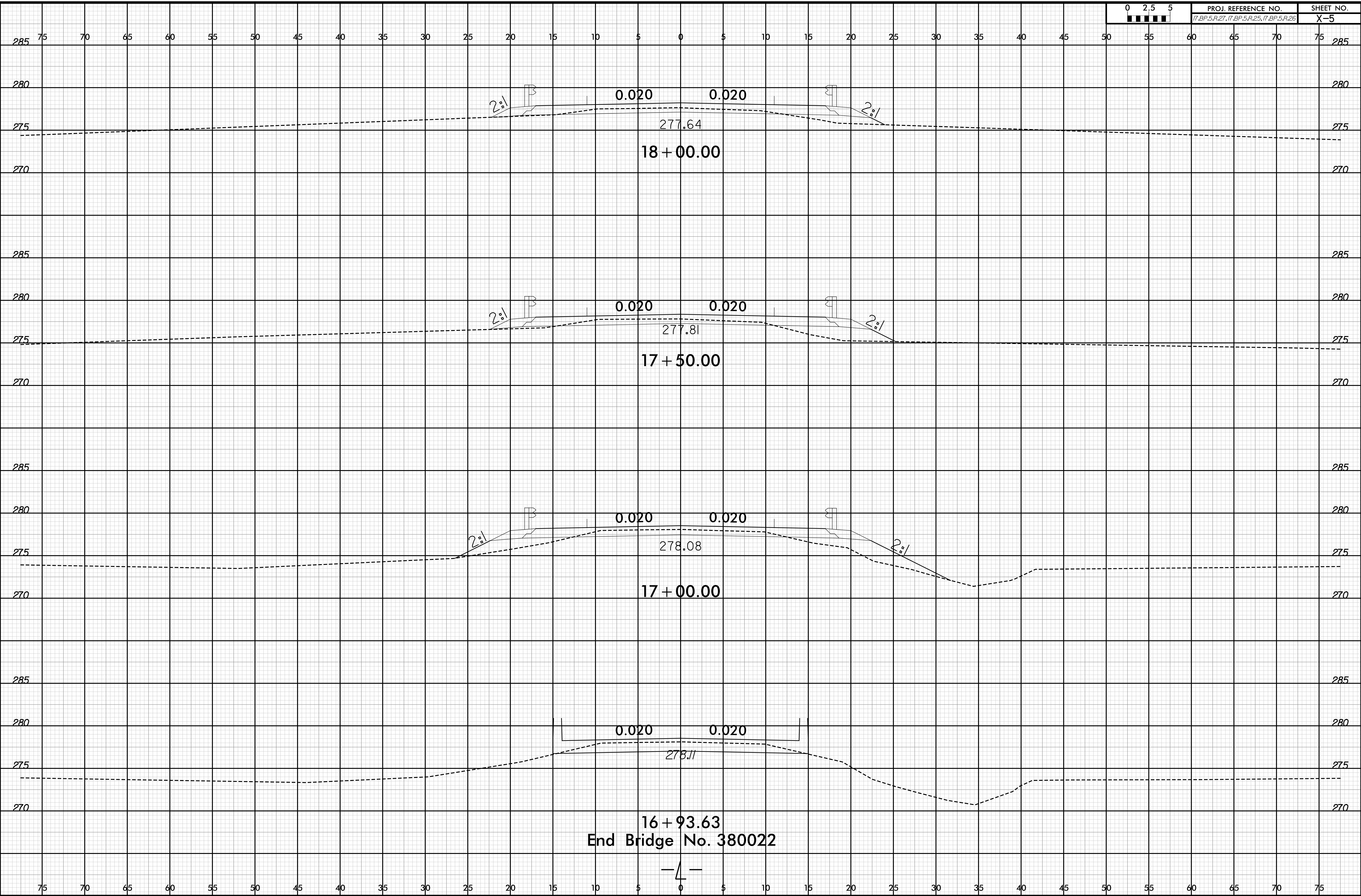

2/13/2013  
17.BP.5.R.26\_r.dwg\_xpl.dgn

8/23/99



PROJ. REFERENCE NO.  
17.BP.5.R.27, 17.BP.5.R.25, 17.BP.5.R.26

SHEET NO.  
X-6

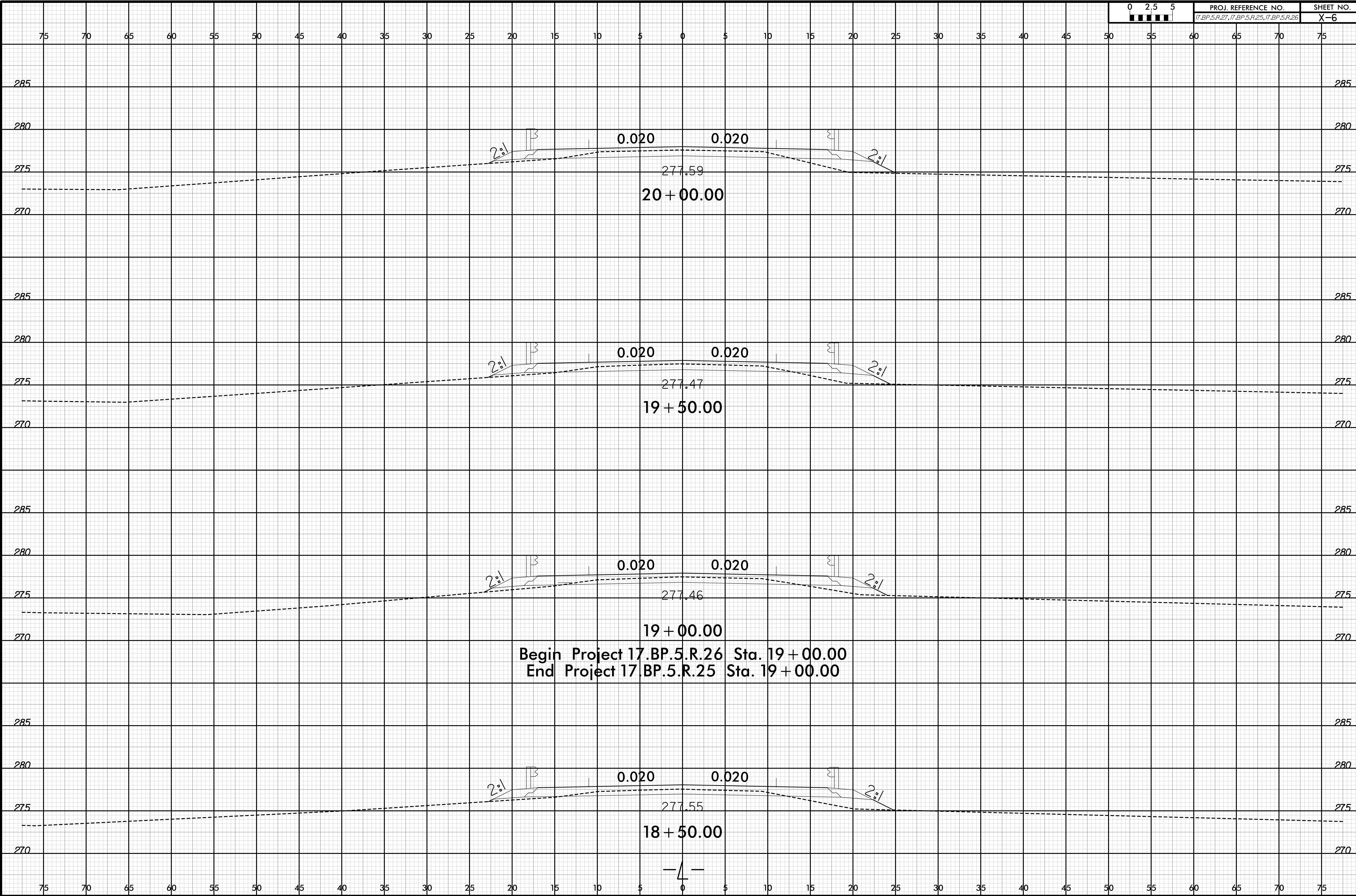

2/13/2013  
17.BP.5.R.26\_r.dwg\_xpl.dgn



8/23/99

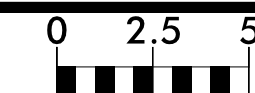

PROJ. REFERENCE NO.  
17.BP.5.R.27, 17.BP.5.R.25, 17.BP.5.R.26

SHEET NO.  
X-7

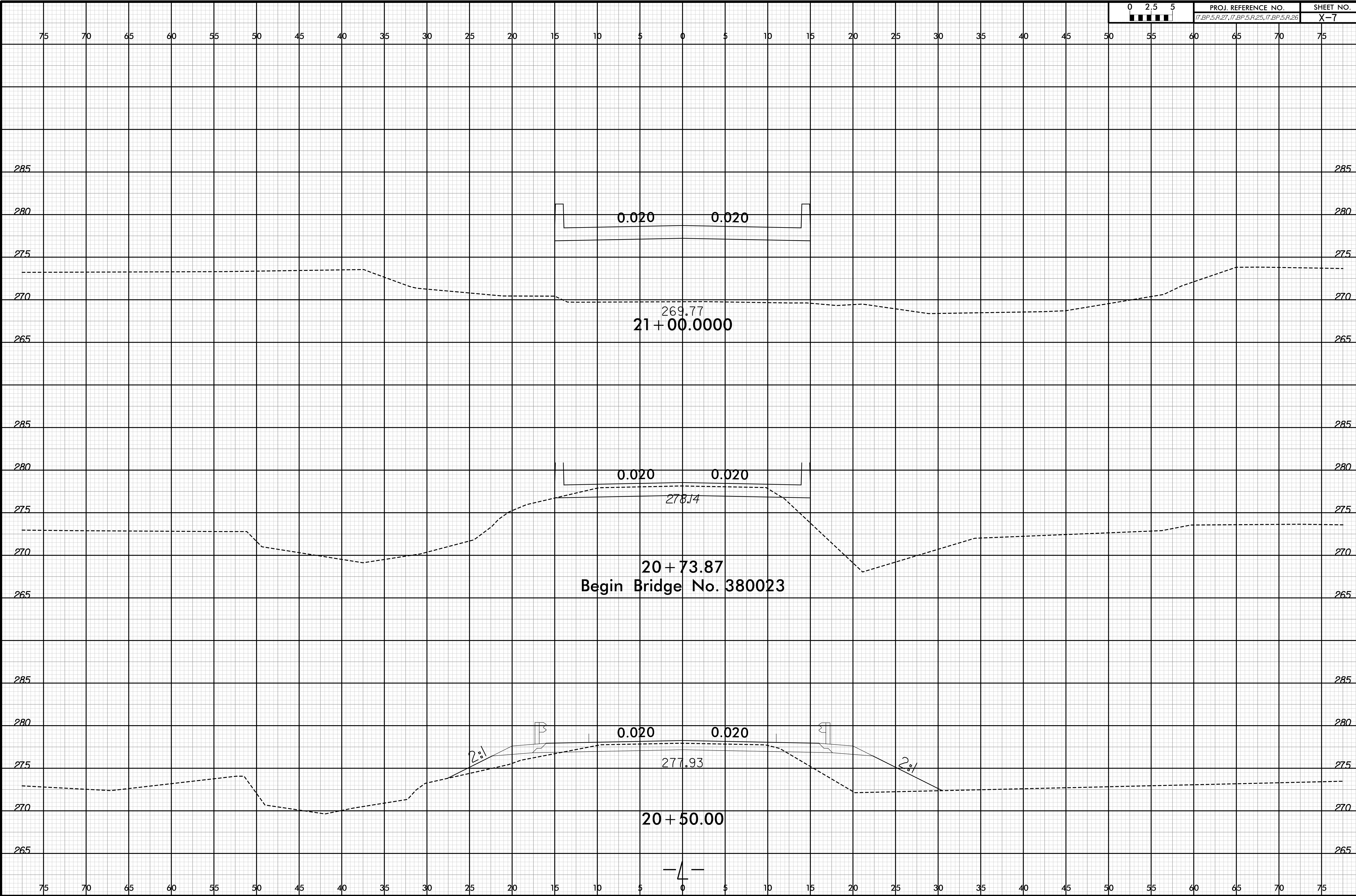

0.020 0.020

269.77  
21 + 00.000

0.020 0.020

278.14  
20 + 73.87  
Begin Bridge No. 380023

0.020 0.020

277.93  
20 + 50.00

2:1

2:1

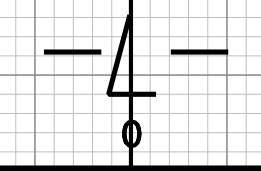

2/13/2013  
17.BP.5.R.26\_r.dwg\_xpl.dgn

8/23/99

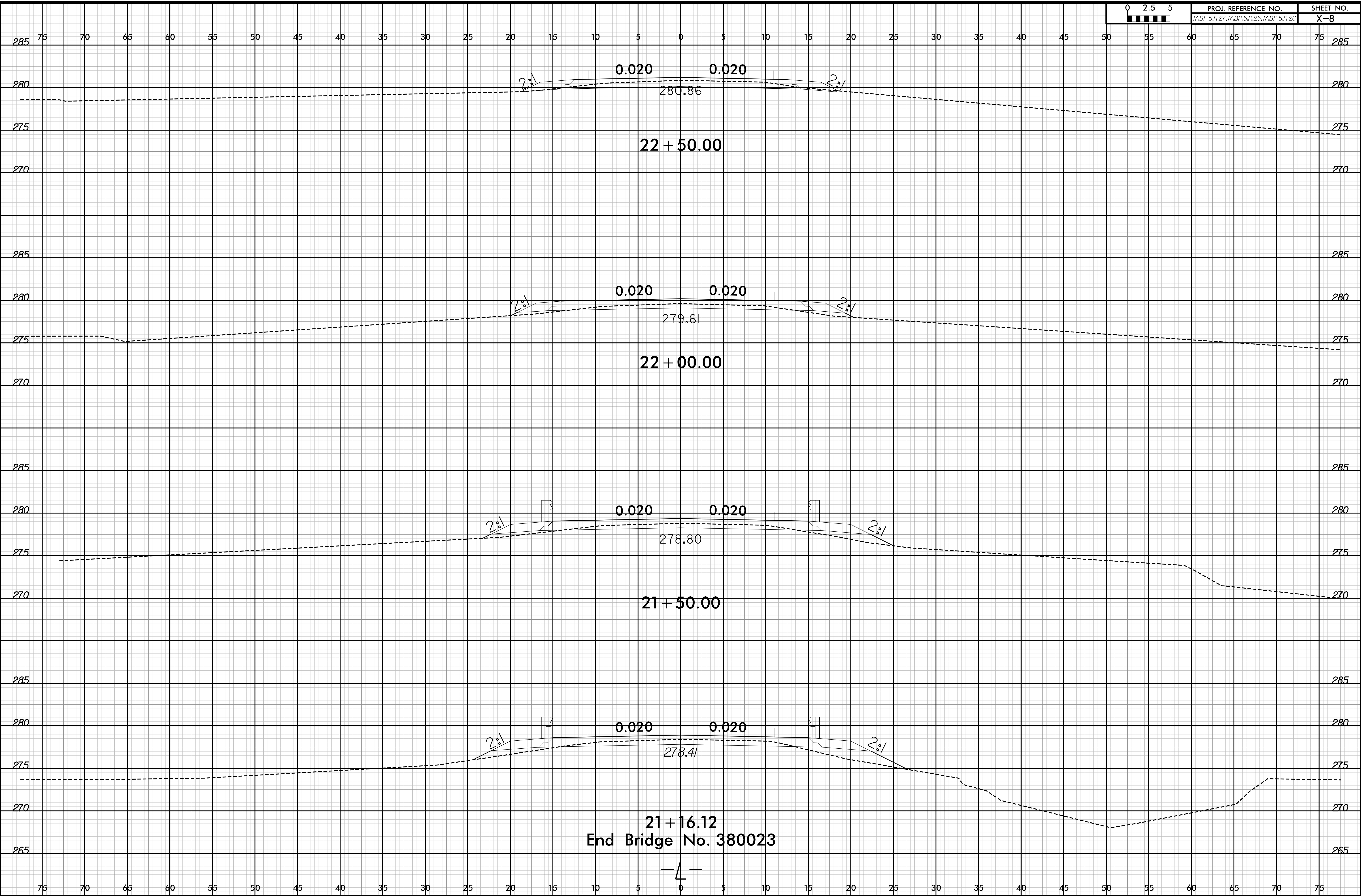

2/13/2013 17.BP.5.R.26\_r.dwg\_xpl.dgn

21+16.12  
End Bridge No. 380023



8/23/99



PROJ. REFERENCE NO.  
17.BP.5.R.27, 17.BP.5.R.25, 17.BP.5.R.26

SHEET NO.  
X-9

75 70 65 60 55 50 45 40 35 30 25 20 15 10 5 0 5 10 15 20 25 30 35 40 45 50 55 60 65 70 75

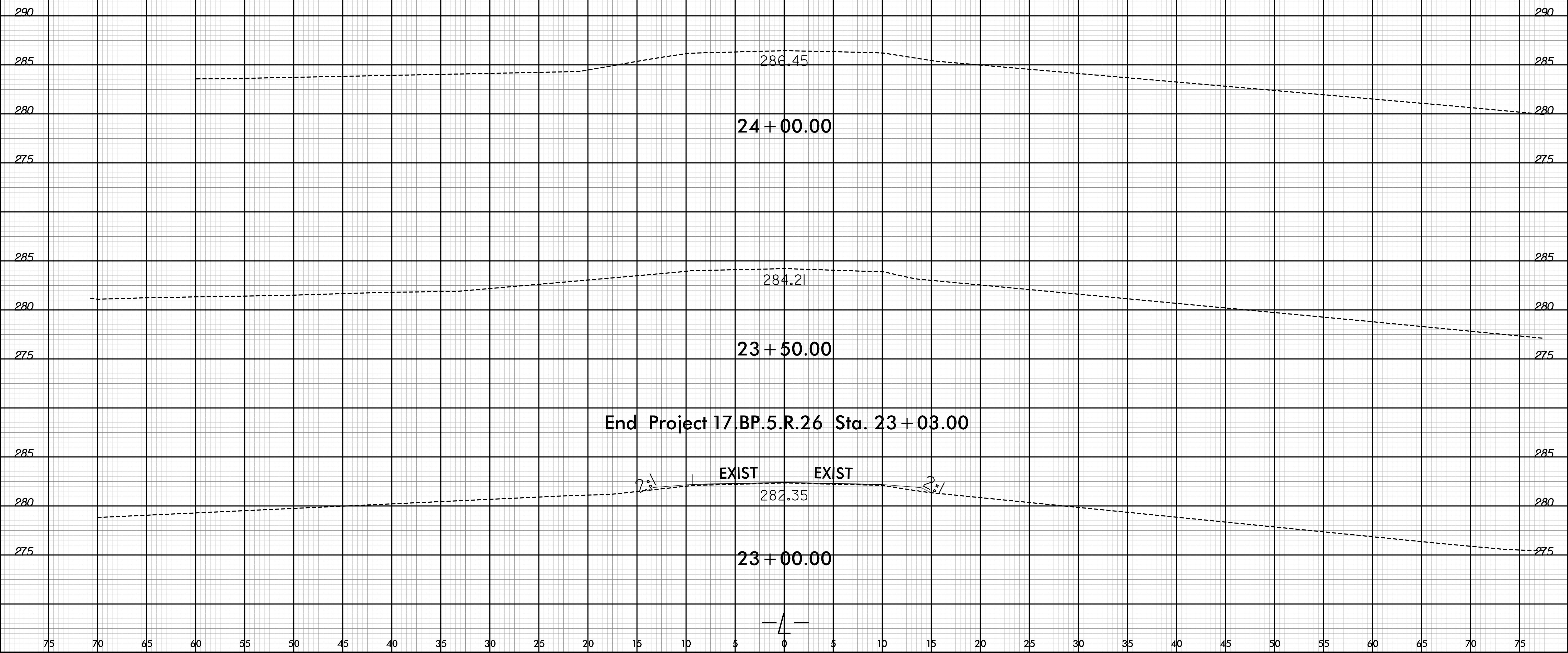

2/13/2013  
17.BP.5.R.26\_r.dwg\_xpl.dgn

STATE	STATE PROJECT REFERENCE NO.	SHEET NO.	TOTAL SHEETS
N.C.	17BP.5.R.27-25-26	EC-1	
STATE PROJ. NO.	F.A. PROJ. NO.	DESCRIPTION	

**EROSION AND SEDIMENT CONTROL MEASURES**

Std. #	Description	Symbol
1630.03	Temporary Silt Ditch	TD
1630.05	Temporary Diversion	TD
1605.01	Temporary Silt Fence	III III III
1606.01	Special Sediment Control Fence	▲▲▲▲▲▲
1622.01	Temporary Berms and Slope Drains	▲▲▲▲▲▲
1630.02	Silt Basin Type B	▨
1633.01	Temporary Rock Silt Check Type-A	▨
	Temporary Rock Silt Check Type-A with Matting and Polyacrylamide (PAM)	▨
1633.02	Temporary Rock Silt Check Type-B	▨
	Wattle/Coir Fiber Wattle	▨
	Wattle/Coir Fiber Wattle with Polyacrylamide (PAM)	▨
1634.01	Temporary Rock Sediment Dam Type-A	▨
1634.02	Temporary Rock Sediment Dam Type-B	▨
1635.01	Rock Pipe Inlet Sediment Trap Type-A	U
1635.02	Rock Pipe Inlet Sediment Trap Type-B	U
1630.04	Stilling Basin	▨
1630.06	Special Stilling Basin	▨
	Rock Inlet Sediment Trap:	
1632.01	Type A	A
1632.02	Type B	B
1632.03	Type C	C
	Skimmer Basin	▨
	Tiered Skimmer Basin	▨
	Infiltration Basin	▨

**TIP PROJECT: 17BP.5.R.27-25-26**

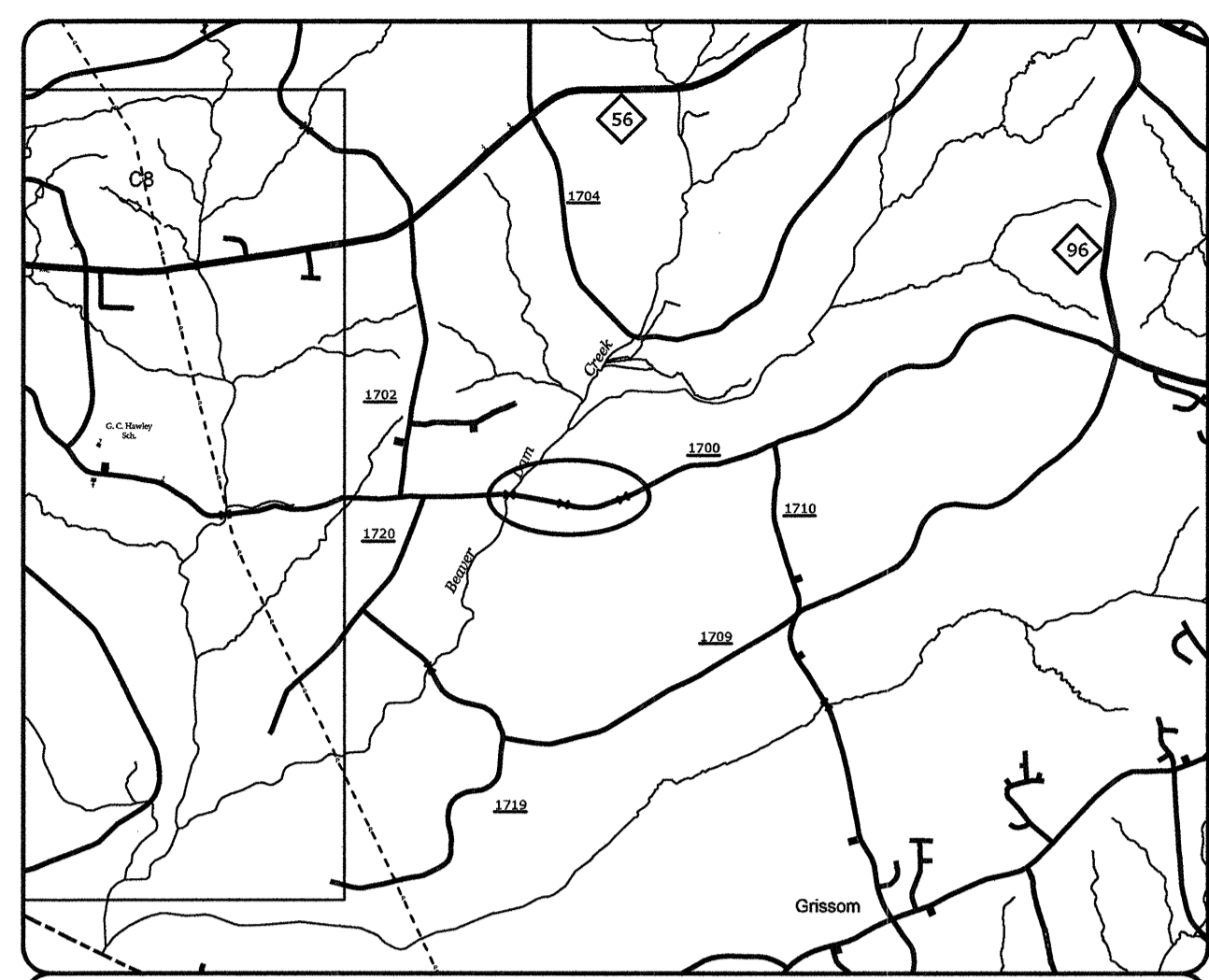

**VICINITY MAP**

— OFFSITE DETOUR

STATE OF NORTH CAROLINA  
DIVISION OF HIGHWAYS  
**PLAN FOR PROPOSED  
HIGHWAY EROSION CONTROL**

**GRANVILLE COUNTY**

**LOCATION: BRIDGE NO. 21, 22, 23 ON SR 1700 OVER  
BRANCH BEAVERDAM CREEK**

**TYPE OF WORK: GRADING, PAVING, DRAINAGE & STRUCTURE**

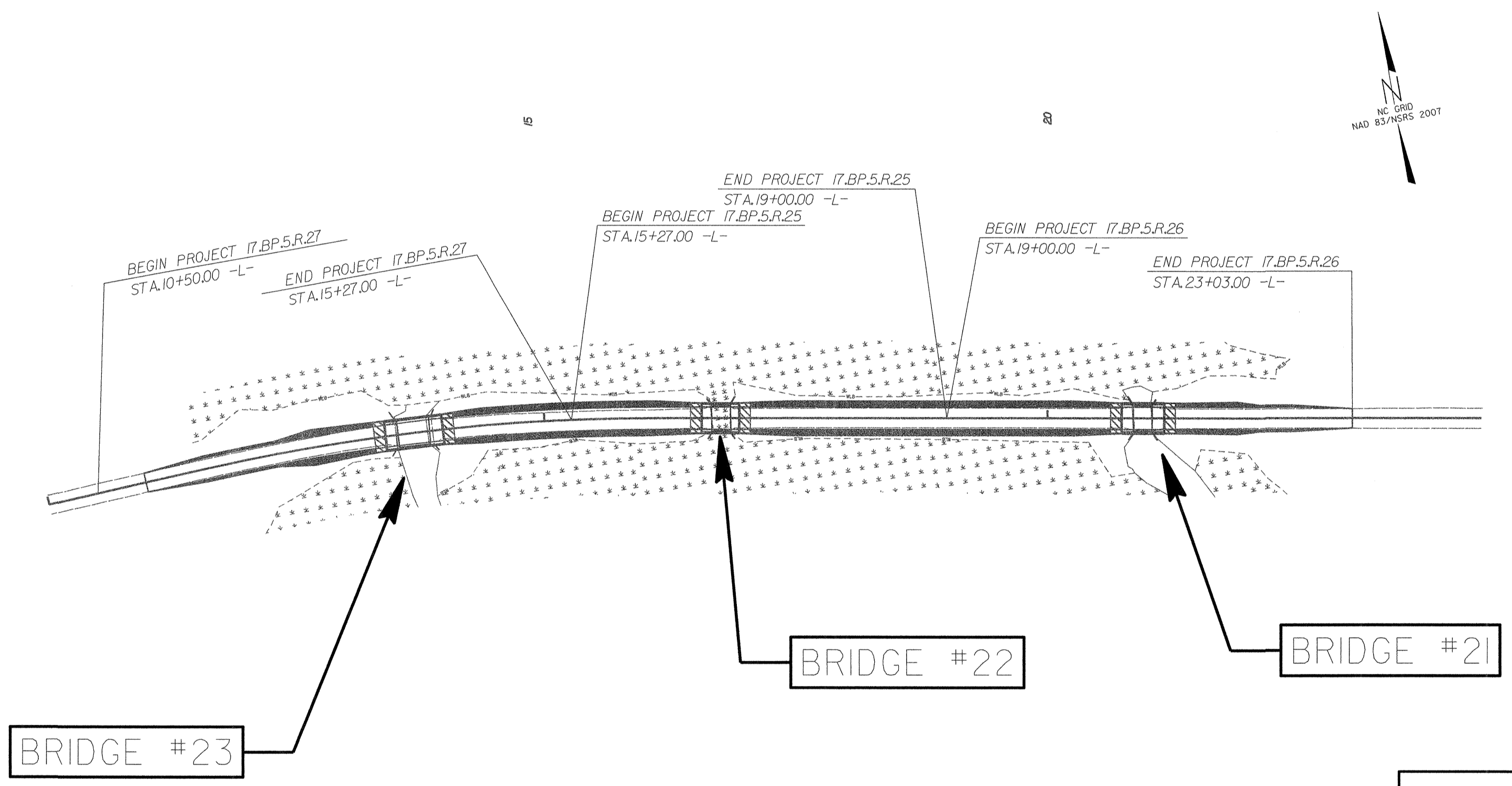

**THIS PROJECT CONTAINS  
EROSION CONTROL PLANS  
FOR CLEARING AND  
GRUBBING PHASE OF  
CONSTRUCTION.**

**THIS PROJECT HAS  
BEEN DESIGNED TO  
SENSITIVE WATERSHED  
STANDARDS.**

**ENVIRONMENTALLY  
SENSITIVE AREA(S) EXIST  
ON THIS PROJECT**

*Refer To E. C. Special Provisions  
for Special Considerations.*

**JOSHUA G. DALTON, PE, CPESC**  
LEVEL IIIA NAME  
  
307  
LEVEL IIIA CERTIFICATION NO.

*2012 STANDARD SPECIFICATIONS*

**GRAPHIC SCALE**

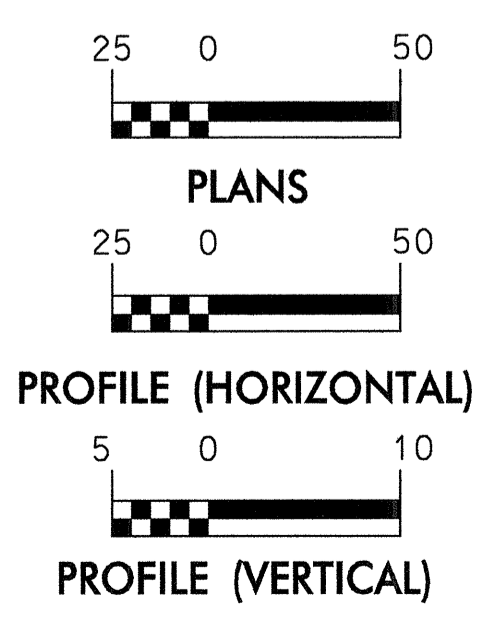

**HYDRAULICS ENGINEER**

SIGNATURE: \_\_\_\_\_ P.E.  
 2/2/13

**THESE EROSION AND SEDIMENT CONTROL PLANS COMPLY  
WITH THE REGULATIONS SET FORTH BY THE  
NCG-010000 GENERAL CONSTRUCTION PERMIT EFFECTIVE AUGUST 3, 2011  
ISSUED BY THE NORTH CAROLINA DEPARTMENT OF ENVIRONMENT AND  
NATURAL RESOURCES DIVISION OF WATER QUALITY.**

*Prepared In the Office of:*

**SUNGATE DESIGN GROUP, P.A.**

915 JONES FRANKLIN ROAD  
 RALEIGH, NORTH CAROLINA 27606  
 TEL (919) 859-2243 FAX (919) 859-6258  
 ENG FIRM LICENSE NO. C-890

**Roadway Standard Drawings**

The following roadway english standards as appear in "Roadway Standard Drawings"- Roadway Design Unit - N. C. Department of Transportation - Raleigh, N. C., dated January 2012 and the latest revision thereto are applicable to this project and by reference hereby are considered a part of these plans.

1604.01 Railroad Erosion Control Detail	1632.01 Rock Inlet Sediment Trap Type A
1605.01 Temporary Silt Fence	1632.02 Rock Inlet Sediment Trap Type B
1606.01 Special Sediment Control Fence	1632.03 Rock Inlet Sediment Trap Type C
1607.01 Gravel Construction Entrance	1633.01 Temporary Rock Silt Check Type A
1622.01 Temporary Berms and Slope Drains	1633.02 Temporary Rock Silt Check Type B
1630.01 Riser Basin	1634.01 Temporary Rock Sediment Dam Type A
1630.02 Silt Basin Type B	1634.02 Temporary Rock Sediment Dam Type B
1630.03 Temporary Silt Ditch	1635.01 Rock Pipe Inlet Sediment Trap Type A
1630.04 Stilling Basin	1635.02 Rock Pipe Inlet Sediment Trap Type B
1630.05 Temporary Diversion	1640.01 Coir Fiber Baffle
1630.06 Special Stilling Basin	1645.01 Temporary Stream Crossing
1631.01 Matting Installation	



# SILT FENCE COIR FIBER WATTLE BREAK DETAIL

PROJECT REFERENCE NO. 17BP.5.R.27-25-26	SHEET NO. EC-2
RW SHEET NO.	
ROADWAY DESIGN ENGINEER	HYDRAULICS ENGINEER

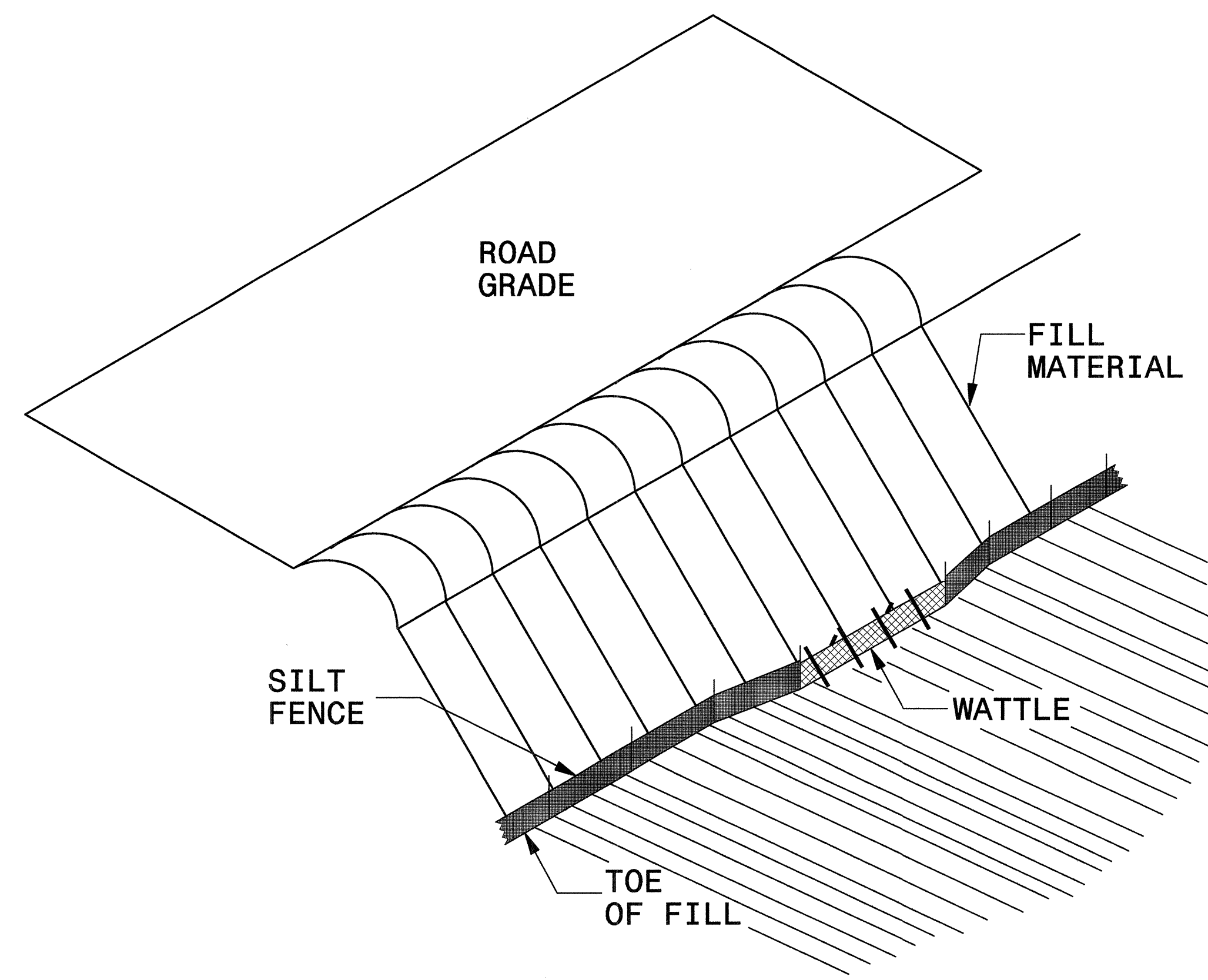

**ISOMETRIC VIEW**

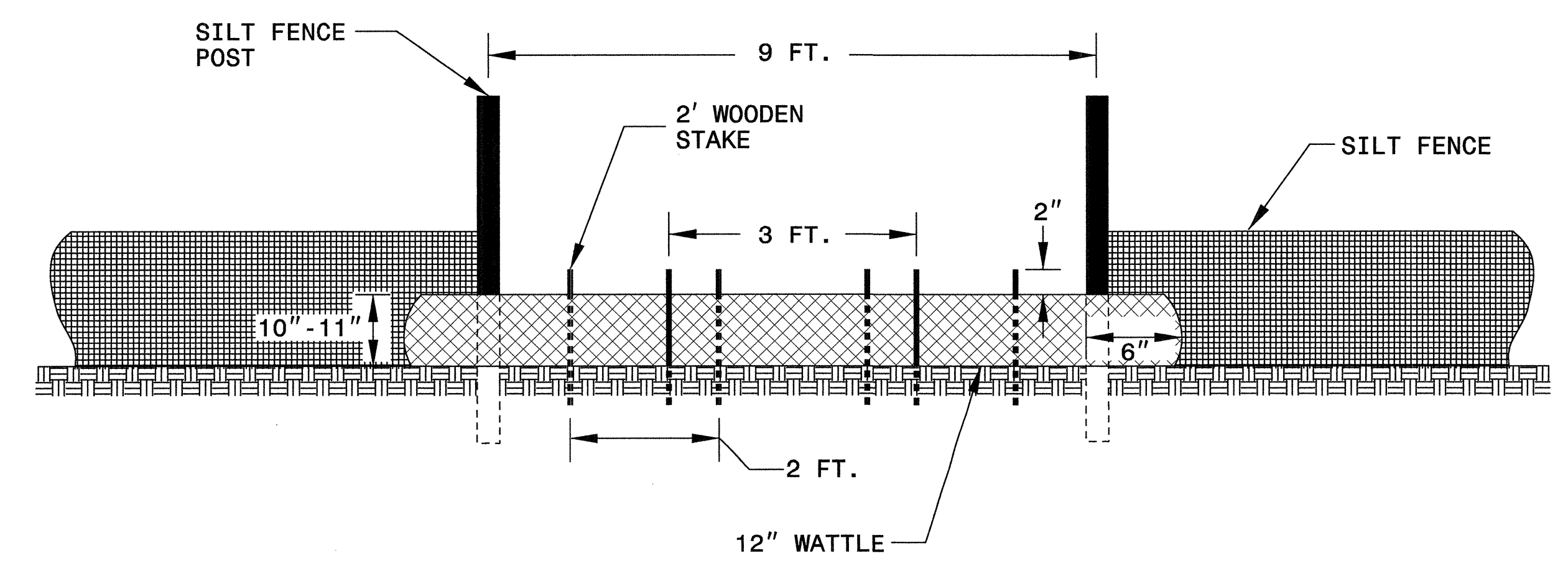

**VIEW FROM SLOPE**

**NOTES:**

- USE MINIMUM 12 IN. DIAMETER COIR FIBER (COCONUT FIBER) WATTLE AND LENGTH OF 10 FT.
- EXCAVATE A 1 TO 2 INCH TRENCH FOR WATTLE TO BE PLACED.
- DO NOT PLACE WATTLE ON TOE OF SLOPE.
- USE 2 FT. WOODEN STAKES WITH A 2 IN. BY 2 IN. NOMINAL CROSS SECTION.
- INSTALL A MINIMUM OF 2 UPSLOPE STAKES AND 4 DOWNSLOPE STAKES AT AN ANGLE TO WEDGE WATTLE TO GROUND.
- PROVIDE STAPLES MADE OF 0.125 IN. DIAMETER STEEL WIRE FORMED INTO A U SHAPE NOT LESS THAN 12" IN LENGTH.
- INSTALL STAPLES APPROXIMATELY EVERY 1 LINEAR FOOT ON BOTH SIDES OF WATTLE AND AT EACH END TO SECURE IT TO THE SOIL.
- WATTLE INSTALLATION CAN BE ON OUTSIDE OF THE SILT FENCE AS DIRECTED.
- INSTALL TEMPORARY SILT FENCE IN ACCORDANCE WITH SECTION 1605 OF THE STANDARD SPECIFICATIONS.

**INSET A**

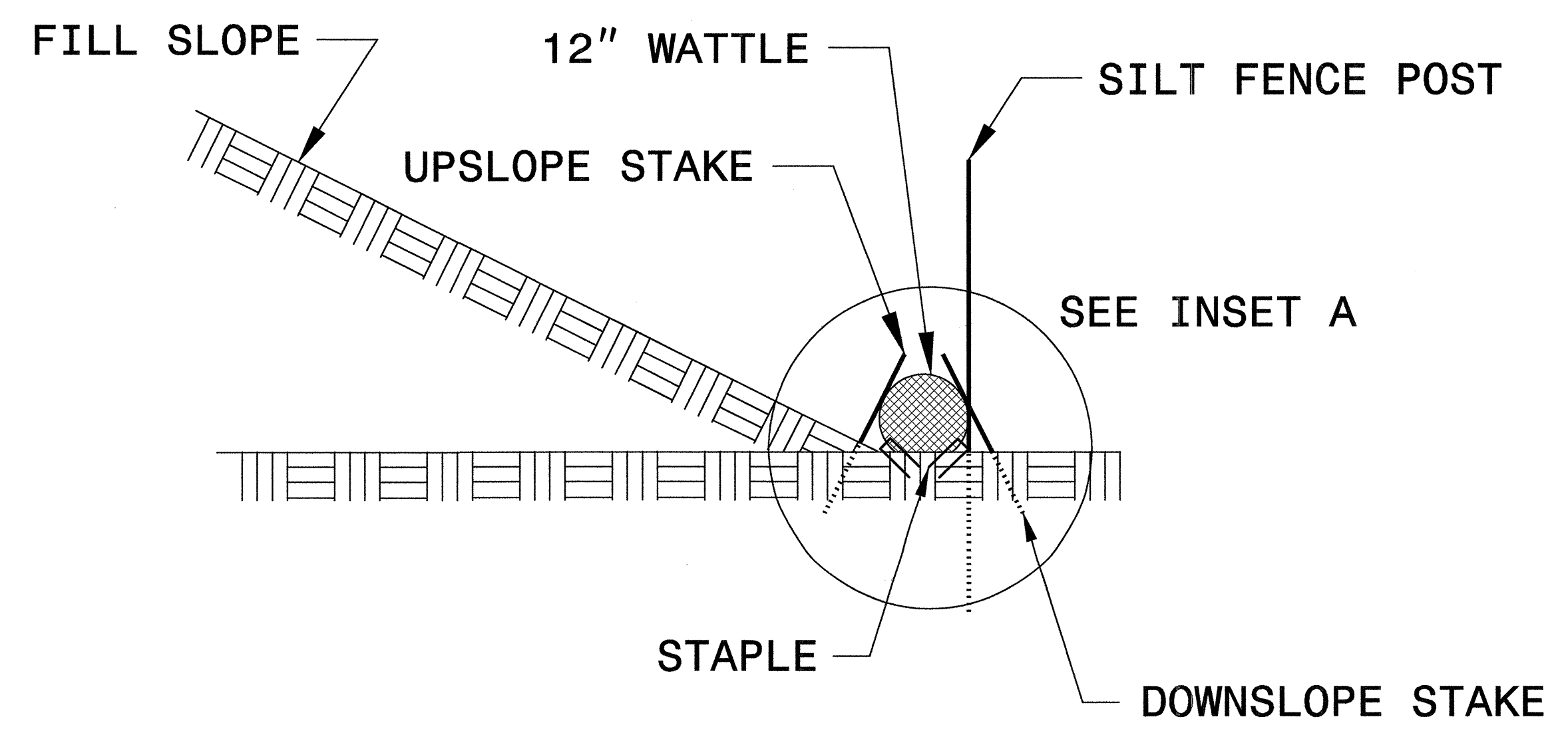
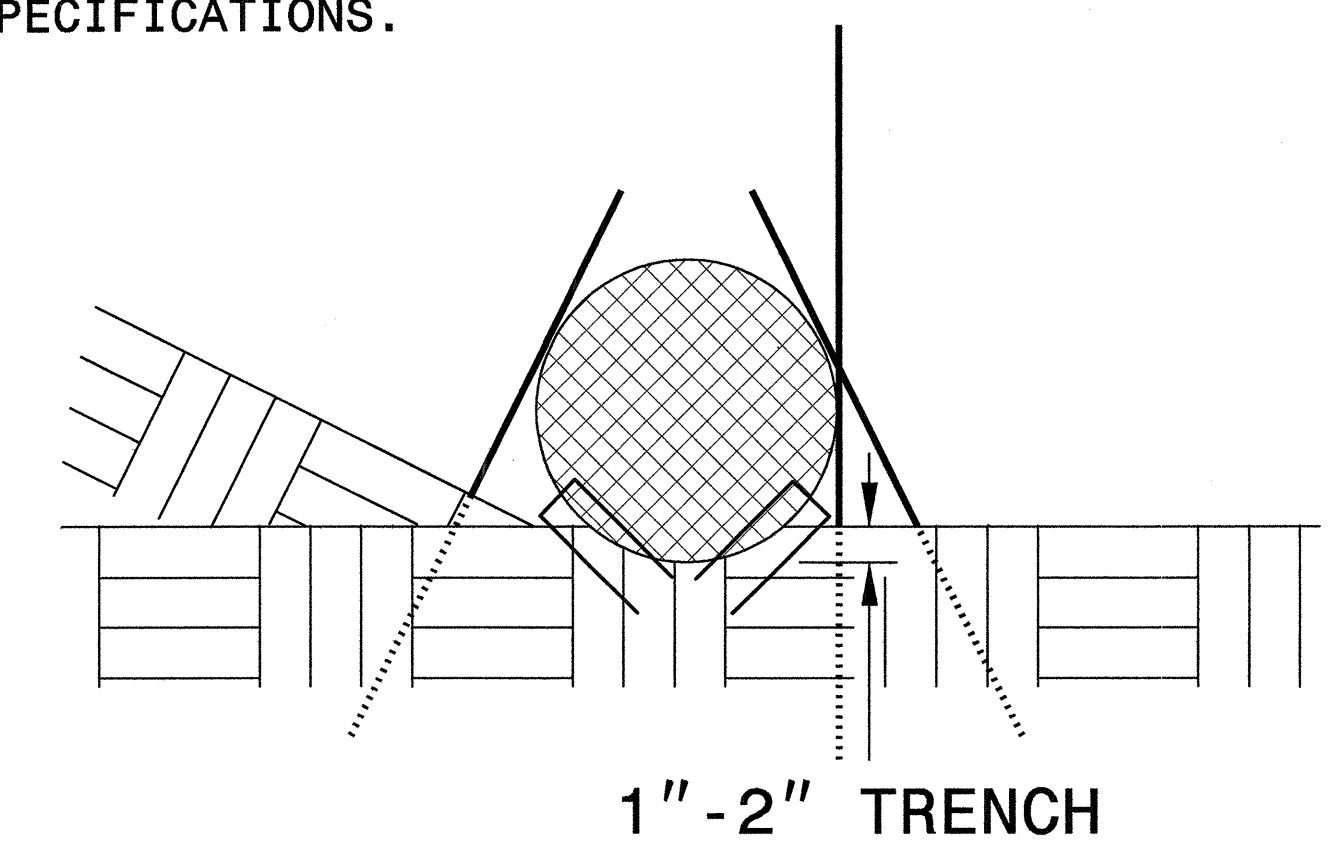

**SIDE VIEW**

PROJECT REFERENCE NO. 17BP.5.R.27-25-26	SHEET NO. EC-2A
RW SHEET NO.	
ROADWAY DESIGN ENGINEER	HYDRAULICS ENGINEER

# COIR FIBER WATTLE WITH POLYACRYLAMIDE (PAM) DETAIL

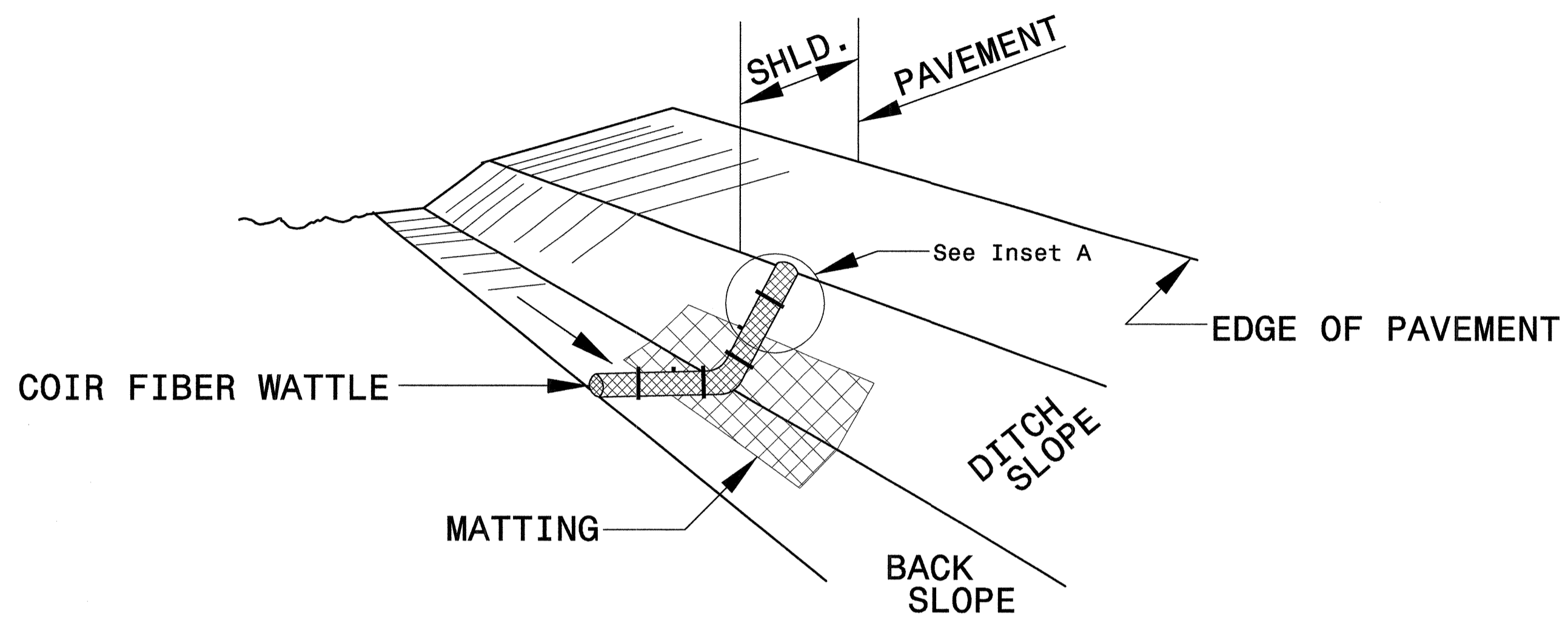

**ISOMETRIC VIEW**

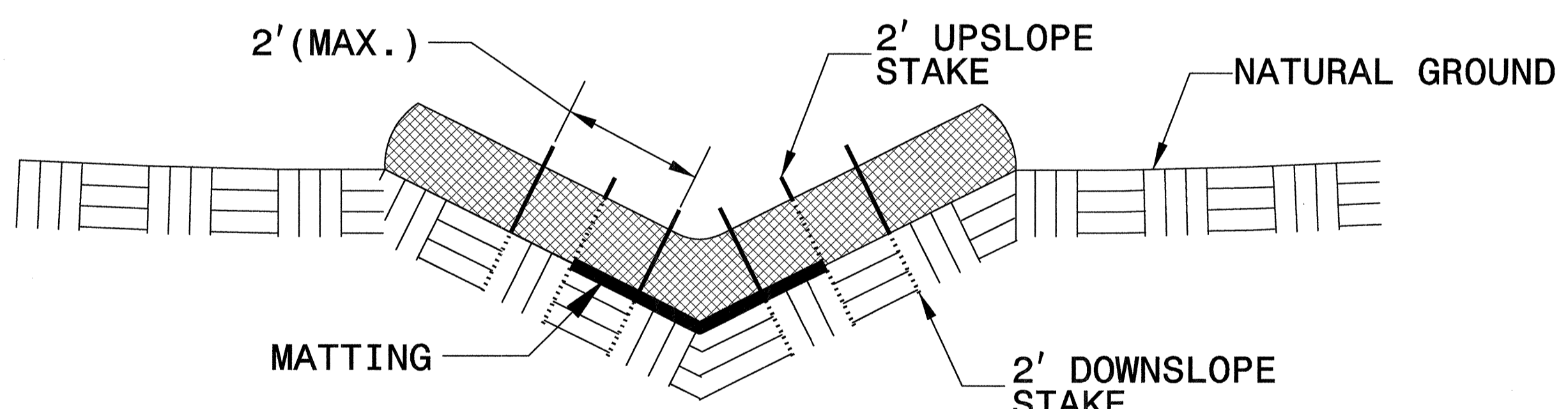

**CROSS SECTION VEE DITCH**

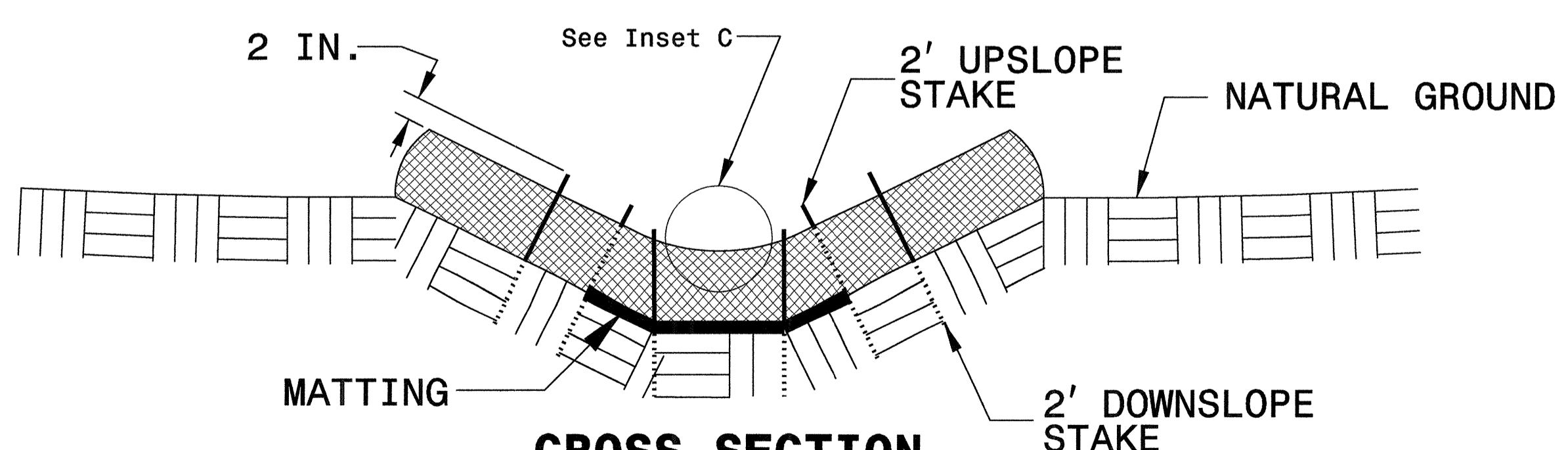

**CROSS SECTION TRAPEZOIDAL DITCH**

- NOTES:
- USE MINIMUM 12 IN. DIAMETER COIR FIBER (COCONUT FIBER) WATTLE.
  - USE 2 FT. WOODEN STAKES WITH A 2 IN. BY 2 IN. NOMINAL CROSS SECTION.
  - ONLY INSTALL WATTLE(S) TO A HEIGHT IN DITCH SO FLOW WILL NOT WASH AROUND WATTLE AND SCOUR DITCH SLOPES AND AS DIRECTED.
  - INSTALL A MINIMUM OF 2 UPSLOPE STAKES AND 4 DOWNSLOPE STAKES AT AN ANGLE TO WEDGE WATTLE TO BOTTOM OF DITCH.
  - PROVIDE STAPLES MADE OF 0.125 IN. DIAMETER STEEL WIRE FORMED INTO A U SHAPE NOT LESS THAN 12" IN LENGTH.
  - INSTALL STAPLES APPROXIMATELY EVERY 1 LINEAR FOOT ON BOTH SIDES OF WATTLE AND AT EACH END TO SECURE IT TO THE SOIL.
  - INSTALL MATTING IN ACCORDANCE WITH SECTION 1631 OF THE STANDARD SPECIFICATIONS.
  - PRIOR TO POLYACRYLAMIDE (PAM) APPLICATION, OBTAIN A SOIL SAMPLE FROM PROJECT LOCATION, AND FROM OFFSITE MATERIAL, AND ANALYZE FOR APPROPRIATE PAM FLOCCULANT TO BE APPLIED TO EACH WATTLE.
  - INITIALLY APPLY 2 OUNCES OF ANIONIC OR NEUTRALLY CHARGED PAM OVER WATTLE WHERE WATER WILL FLOW AND 1 OUNCE OF PAM ON MATTING ON EACH SIDE OF WATTLE. REAPPLY PAM AFTER EVERY RAINFALL EVENT THAT IS EQUAL TO OR EXCEEDS 0.50 IN.

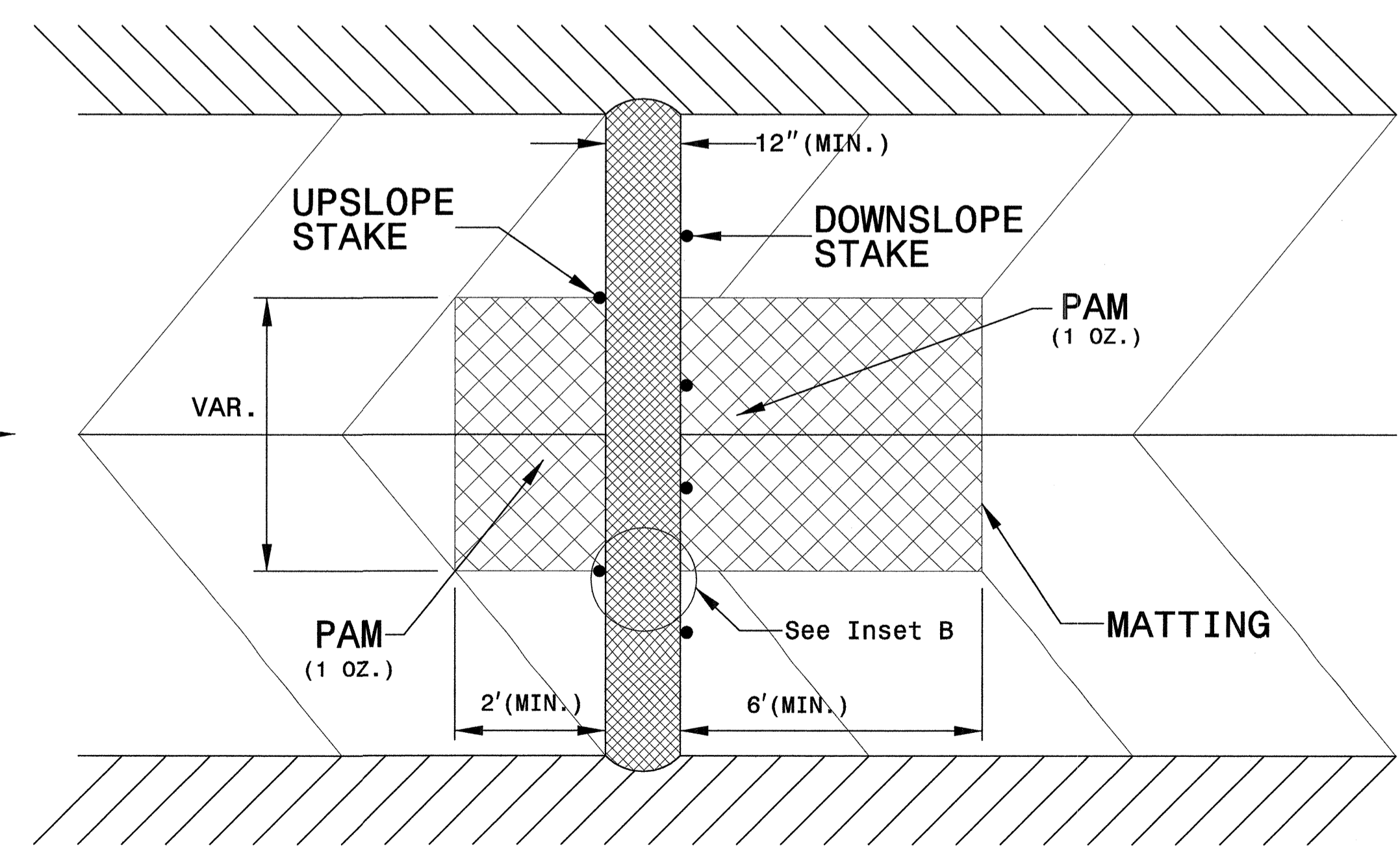
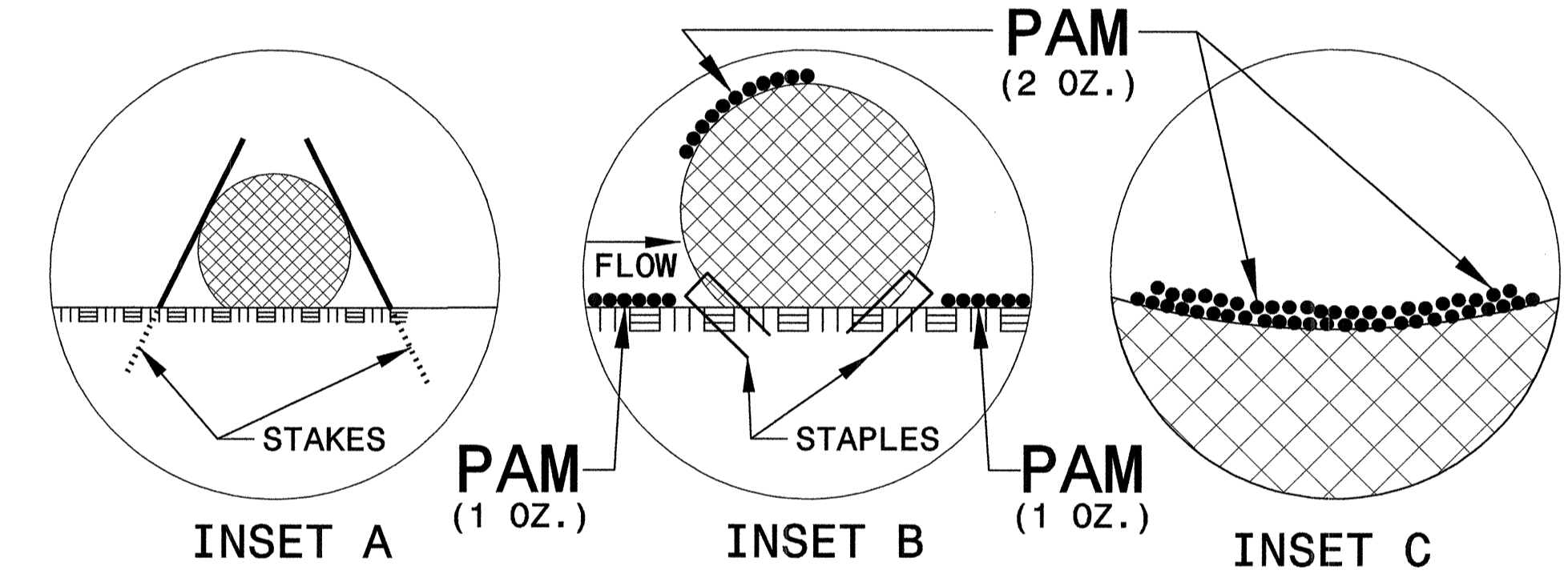

**TOP VIEW**



PROJECT REFERENCE NO. 17BP.5.R.27-25-26	SHEET NO. EC-2B
RW SHEET NO.	
ROADWAY DESIGN ENGINEER	HYDRAULICS ENGINEER

# COIR FIBER WATTLE BARRIER DETAIL

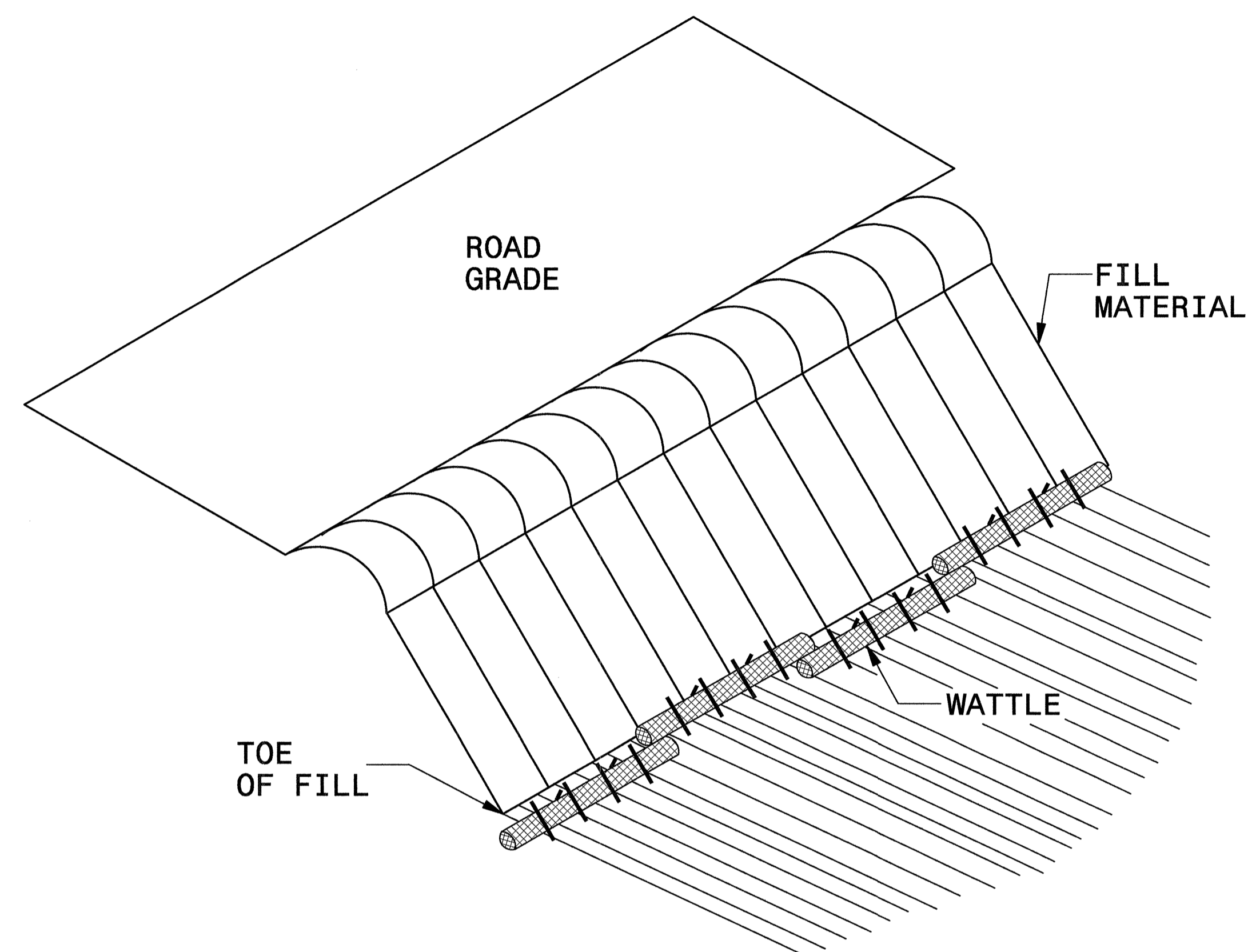

**ISOMETRIC VIEW**

**NOTES:**

USE MINIMUM 12 IN. DIAMETER COIR FIBER (COCONUT) WATTLE AND LENGTH OF 10 FT.

EXCAVATE A 1 TO 2 INCH TRENCH FOR WATTLE TO BE PLACED.

DO NOT PLACE WATTLES ON TOE OF SLOPE.

USE 2 FT. WOODEN STAKES WITH A 2 IN. BY 2 IN. NOMINAL CROSS SECTION.

INSTALL A MINIMUM OF 2 UPSLOPE STAKES AND 4 DOWNSLOPE STAKES AT AN ANGLE TO WEDGE WATTLE TO GROUND.

PROVIDE STAPLES MADE OF 0.125 IN. DIAMETER STEEL WIRE FORMED INTO A U SHAPE NOT LESS THAN 12" IN LENGTH.

INSTALL STAPLES APPROXIMATELY EVERY 1 LINEAR FOOT ON BOTH SIDES OF WATTLE AND AT EACH END TO SECURE IT TO THE SOIL.

FOR BREAKS ALONG LARGE SLOPES, USE MAXIMUM SPACING OF 20 FT.

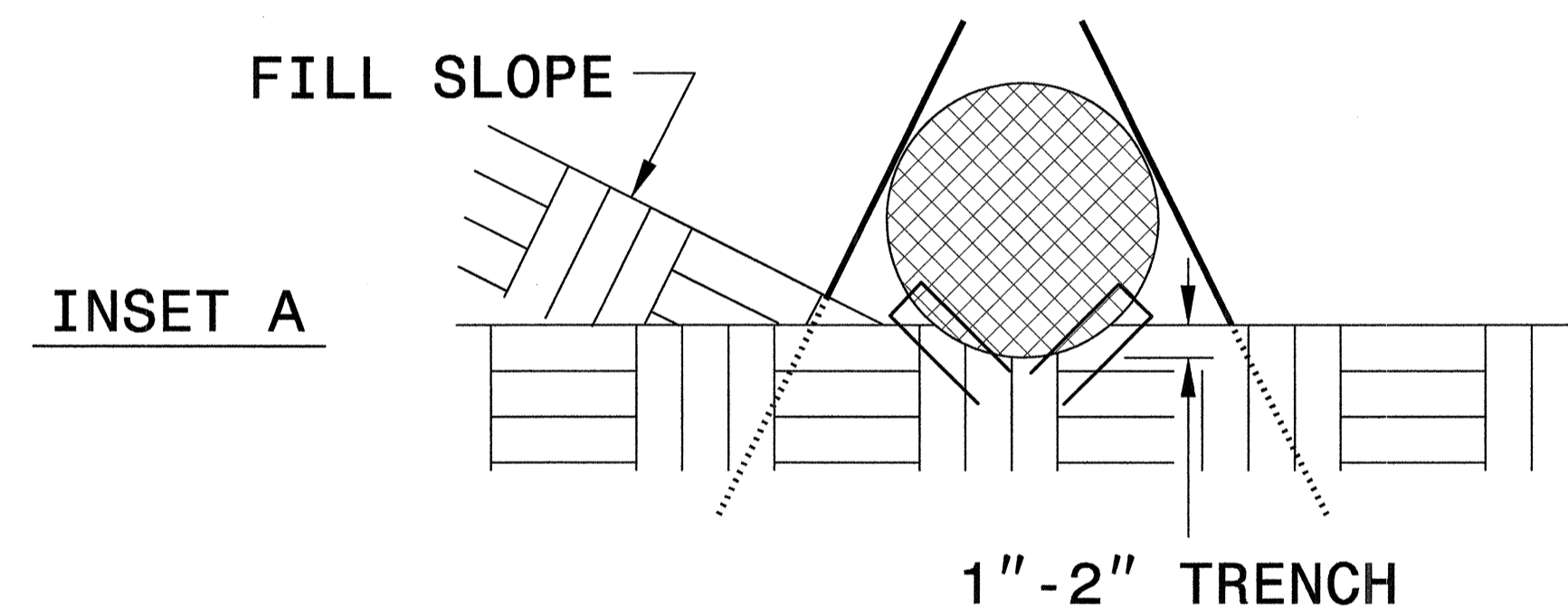

**INSET A**

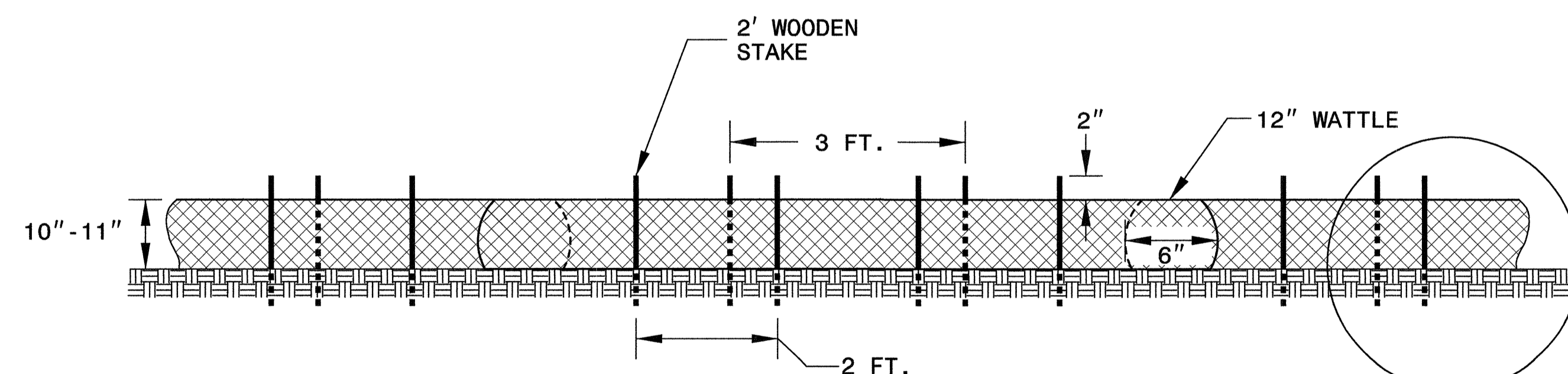

**FRONT VIEW**

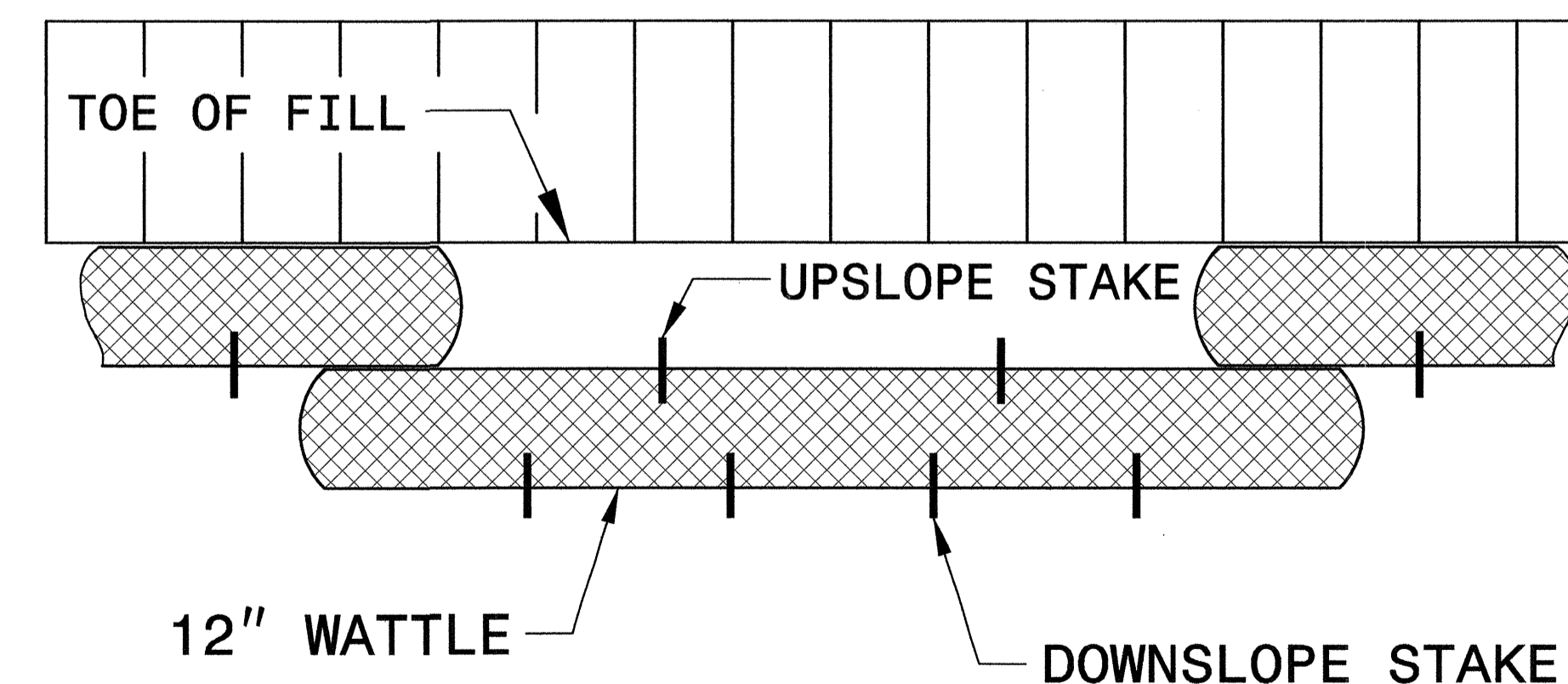

**TOP VIEW**

DIVISION OF HIGHWAYS  
STATE OF NORTH CAROLINA

---



---

PROJECT REFERENCE NO. <i>17BP.5.R.27-25-26</i>	SHEET NO. <i>EC-3</i>
ROADWAY DESIGN ENGINEER	HYDRAULICS ENGINEER

## ***SOIL STABILIZATION TIMEFRAMES***

<i>SITE DESCRIPTION</i>	<i>STABILIZATION TIME</i>	<i>TIMEFRAME EXCEPTIONS</i>
PERIMETER DIKES, SWALES, DITCHES AND SLOPES	7 DAYS	NONE
HIGH QUALITY WATER (HQW) ZONES	7 DAYS	NONE
SLOPES STEEPER THAN 3:1	7 DAYS	IF SLOPES ARE 10' OR LESS IN LENGTH AND ARE NOT STEEPER THAN 2:1, 14 DAYS ARE ALLOWED.
SLOPES 3:1 OR FLATTER	14 DAYS	7 DAYS FOR SLOPES GREATER THAN 50' IN LENGTH.
ALL OTHER AREAS WITH SLOPES FLATTER THAN 4:1	14 DAYS	NONE, EXCEPT FOR PERIMETERS AND HQW ZONES.



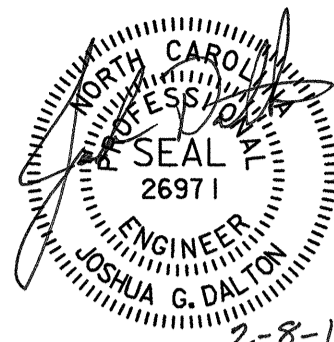

PROJECT REFERENCE NO. 17BP.5.R.27-25-26	SHEET NO. EC-04/CONST.04
RW SHEET NO.	
ROADWAY DESIGN ENGINEER	HYDRAULICS ENGINEER
	
	2-8-13

CLEARING AND GRUBBING  
EROSION CONTROL FOR  
CONSTRUCTION SHEET 4

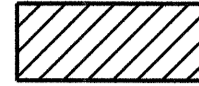
 ENVIRONMENTALLY SENSITIVE AREA  
SEE PROJECT SPECIAL PROVISIONS

USE 15 x 15 SPECIAL STILLING BASIN  
FOR DEWATERING AT EACH BRIDGE.  
LOCATION SHALL BE DETERMINED IN THE FIELD.

REMOVE EXISTING ABUTMENTS AND FOOTINGS.  
PLACE BANK STABILIZATION W/CLASS II RIP RAP (SEE DETAIL #2).  
USE IMPERVIOUS DIKE STANDARD BMP ALONG STREAM BANKS  
TO DEWATER AND ISOLATE ADJACENT WORK AREA TO REMOVE  
EXISTING ABUTMENT AND PILES IN THE DRY. THE PLACEMENT  
OF THE IMPERVIOUS DIKE IS CONSIDERED INCIDENTAL TO THE  
ABUTMENT REMOVAL.

10

15

20

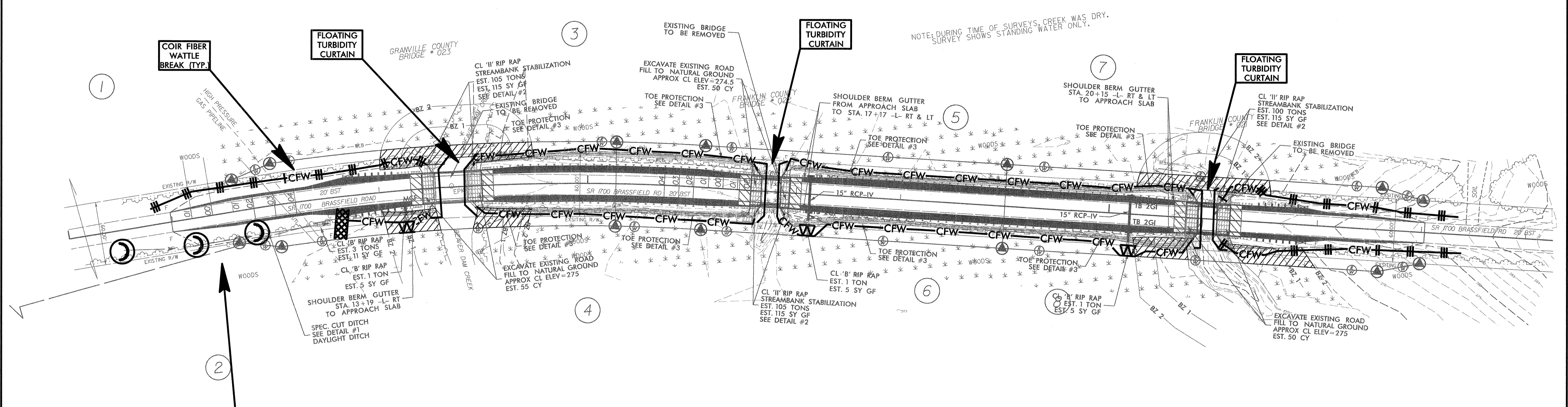

INSTALL MATTING FOR  
EROSION CONTROL IN THE  
PROPOSED DITCH LINE.

Place Matting for Erosion Control  
on Slopes Adjacent to Permitted  
Wetlands as Work Allows.

NOTE:  
TEMPORARY SILT FENCE SHALL BE INSTALLED A MAXIMUM  
OF 3 FEET FROM TOE OF FILL IN WETLAND AREAS

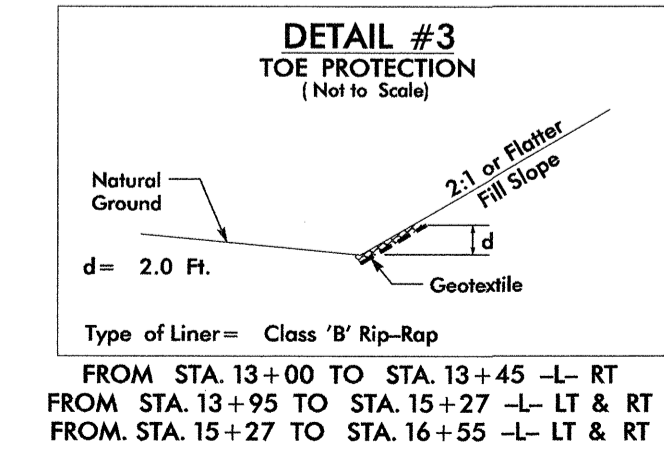
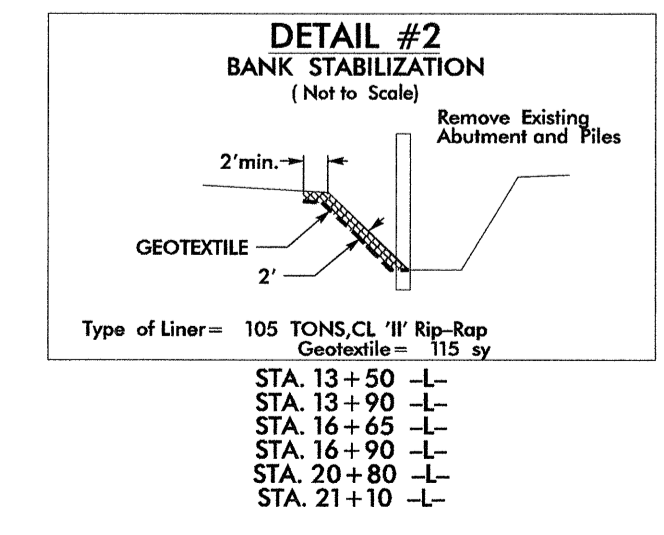
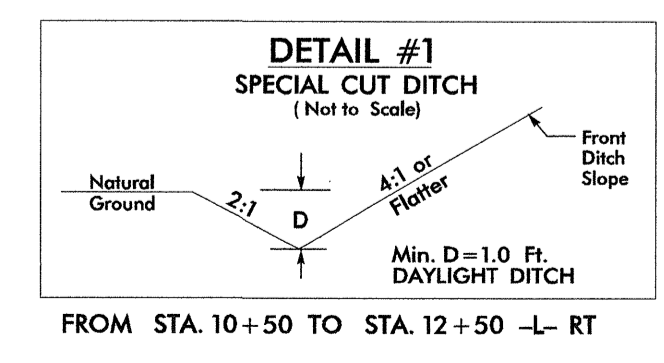

PROJECT REFERENCE NO. 17BP.5.R.27-25-26	SHEET NO. EC-05/CONST.04
RW SHEET NO.	
ROADWAY DESIGN ENGINEER	HYDRAULICS ENGINEER
	2-8-13

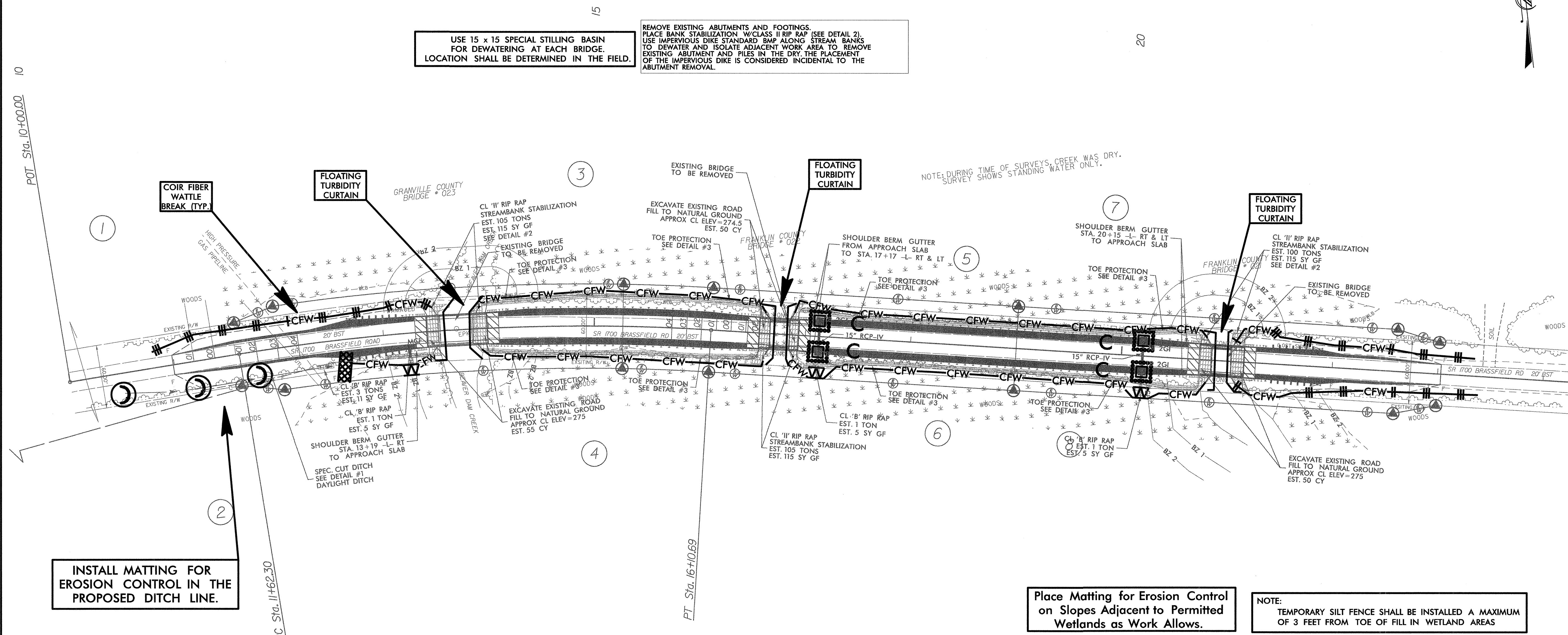

USE 15 x 15 SPECIAL STILLING BASIN FOR DEWATERING AT EACH BRIDGE. LOCATION SHALL BE DETERMINED IN THE FIELD.

REMOVE EXISTING ABUTMENTS AND FOOTINGS. PLACE BANK STABILIZATION W/CLASS II RIP RAP (SEE DETAIL 2). USE IMPERVIOUS DIKE STANDARD BMP ALONG STREAM BANKS TO DEWATER AND ISOLATE ADJACENT WORK AREA TO REMOVE EXISTING ABUTMENT AND PILES IN THE DRY. THE PLACEMENT OF THE IMPERVIOUS DIKE IS CONSIDERED INCIDENTAL TO THE ABUTMENT REMOVAL.

NOTE: DURING TIME OF SURVEYS, CREEK WAS DRY. SURVEY SHOWS STANDING WATER ONLY.

INSTALL MATTING FOR EROSION CONTROL IN THE PROPOSED DITCH LINE.

Place Matting for Erosion Control on Slopes Adjacent to Permitted Wetlands as Work Allows.

NOTE: TEMPORARY SILT FENCE SHALL BE INSTALLED A MAXIMUM OF 3 FEET FROM TOE OF FILL IN WETLAND AREAS

